

Inca Pro 30 insert 600 cfm internal

a fusion of power and style

BUILT-IN
PRO SERIES

- professional-style insert
- fits custom hoods 30" wide and up
- stainless steel finish
- 600 cfm PRO motor
- 2 halogen lights
- 3 speed control
- integrated control panel
- stainless steel baffle filters
- convertible to recirculating*
- built-in mounting system
- sloped front and sides
- sone range: 3.5 - 6.5
- 6" round duct



Finally, a high-powered insert that looks as great as it performs. The Inca Pro 30, with its powerful PRO motor and stylish baffle filter system, offers an all-in-one-box solution for custom ventilating.

* it is highly recommended that professional style cooking always be vented to the outside.



Size/Color/Model #
30 Internal Stainless 630001084

a
c
c
e
s
s
o
r
i
e
s

Inca Pro 30 can be used with custom hoods 30" wide and up. Choose either a custom liner or our ProLiner designed for 36" wide installations.

Liners

Create a perfectly-sealed, non-combustible perimeter around the Inca Pro. Depth adjustable from 21" - 25".

ProLiner 36 Stainless 620000301



Charcoal Filters 6093034

For recirculating installations, high quality, heavy duty filters ensure the removal of smoke and odors from the kitchen. Some ductwork is required to exhaust the unit out of the cabinet.

Dimensional Diagrams

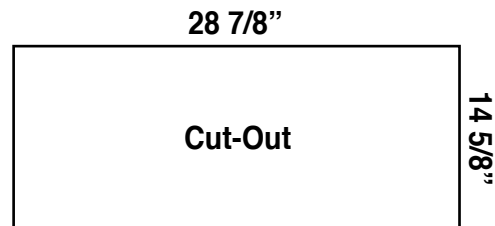
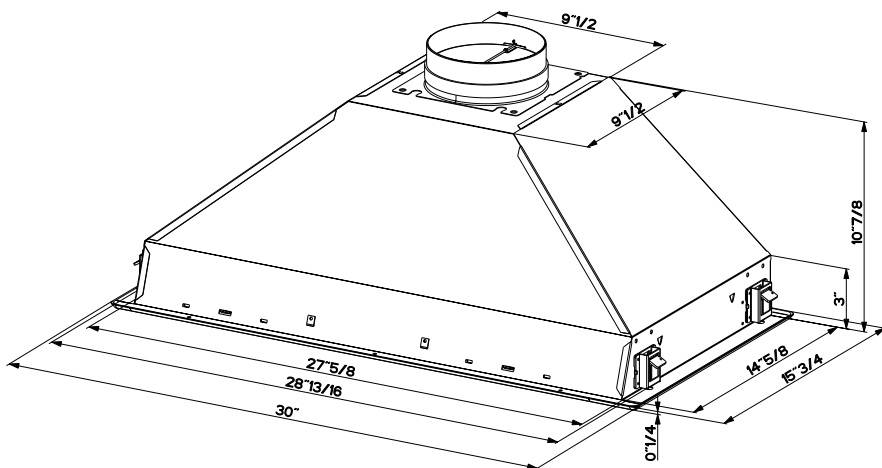

Liners

Create a perfectly-sealed, non-combustible perimeter around the Inca Pro 30. Designed for 36" wide installations. Depth adjustable from 21" - 25"

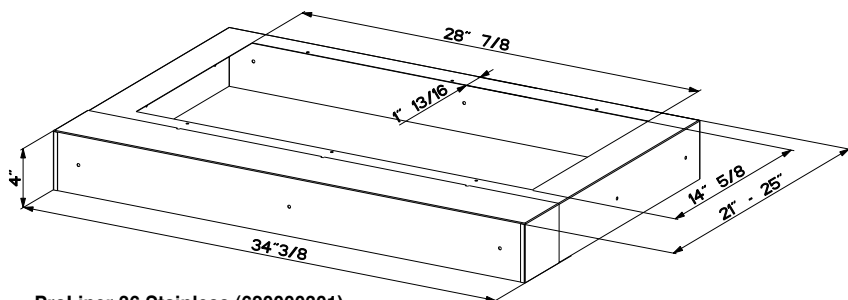

ProLiner 36 Stainless (620000301)
designed for 36" wide installations

Pre-Planning Your Installation - Important: Consult the installation instructions before you begin installing this rangehood. The recommended height to install this hood off the cooktop is a minimum of 30" for maximum effectiveness. Also consult the cooktop manufacturer's recommendation.

Pre-Planning Your Ductwork - Important: Consult the installation instructions before you begin installing this rangehood.

Make your ductrun as short and straight as possible. The ductrun should not exceed 35 equivalent feet if ducted using the required minimum of 6" round duct. Count 45° angles as 3 feet, 90° elbows as 5 feet, and 90° flat elbows as 12 feet.

Recirculating Installations

IT IS HIGHLY RECOMMENDED THAT PROFESSIONAL STYLE COOKING ALWAYS BE VENTED TO THE OUTSIDE. For installations where ductwork is impossible or highly impractical **Charcoal Filters**, which attach to the blower assembly, absorb smoke and odors.

For best results, use no more than three 90° elbows. Make sure that there is a minimum of 24" of straight duct between elbows if more than one is used. Do not install two elbows together. If you must elbow right away, do it as far away from the hood's exhaust opening as possible.

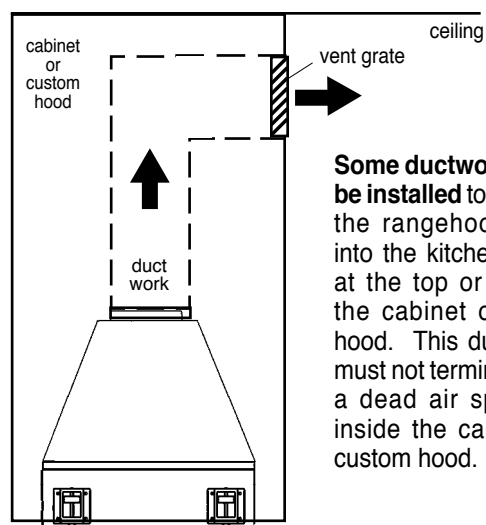
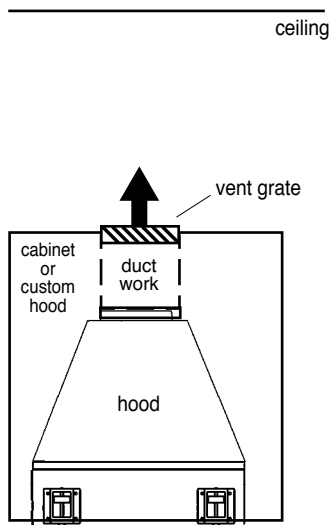

Some ductwork must be installed to exhaust the rangehood back into the kitchen either at the top or face of the cabinet or wood hood. This duct work must not terminate into a dead air space or inside the cabinet or custom hood.

WARNING! Product specifications are subject to change without notification. Consult the installation instructions before you begin installing this rangehood.

Rev.09/05