

PRO 48

PRO  
48

## INSTALLATION INSTRUCTIONS





## CONTENTS

<b>PRO 48 Installation Recommendations</b>	<b>3</b>
<b>PRO 48 Overall Dimensions</b>	<b>4</b>
<b>PRO 48 Installation Specifications</b>	<b>5</b>
<b>PRO 48 Installation Instructions</b>	<b>6</b>
<b>PRO 48 Installation Checklist</b>	<b>14</b>
<b>PRO 48 Service Information</b>	<b>15</b>

*Features and specifications indicated herein and on the website are subject to change at any time without notice. Check our website, [subzero.com](http://subzero.com), for the most up-to-date specifications.*

As you follow these instructions, you will notice **WARNING** and **CAUTION** symbols. This blocked information is important for the safe and efficient installation of Sub-Zero equipment. There are two types of potential hazards that may occur during installation.

### **⚠ CAUTION**

signals a situation where minor injury or product damage may occur if you do not follow instructions.

### **⚠ WARNING**

states a hazard that may cause serious injury or death if precautions are not followed.

Another footnote we would like to identify is **IMPORTANT NOTE**: This highlights information that is especially relevant to a problem-free installation.



**INSTALLATION** RECOMMENDATIONS

The importance of the Sub-Zero PRO 48 installation cannot be overemphasized. The installation procedure should be completed by a qualified installer.

Before you begin the installation process, it is recommended that you read this entire Installation Instructions book. There are key details that you should take special care to observe during the installation. By reading these instructions carefully, you will make the installation process easier, problem-free and, most importantly, safe.

The installation process is identical for both the Model 648PROG which features a glass door on the upper refrigerator compartment and Model 648PRO with a solid door.

Any questions or problems about the installation should be directed to your Sub-Zero dealer or the Sub-Zero Customer Service Department at 800-222-7820. You may also check the service center locator on our website, subzero.com.

**TOOLS AND MATERIALS REQUIRED**

The following is a list of tools and materials that should be available for proper installation of the PRO 48.

- Phillips screwdriver set
- Slotted screwdriver set
- Torx drive screwdriver set
- 4' (1.2 m) of 1/4" copper tubing and saddle valve for the water line—part #4200880 (do not use self-piercing valves)
- Copper tubing cutter
- Level—2' (.6 m) and 4' (1.2 m) recommended
- Appliance Dolly able to support 1000 lbs (454 kg) and adequate manpower to handle the weight of the unit
- Various sized pliers
- Wrench set
- Allen wrench set
- 7/16" hex bolt nut driver
- Crescent wrenches
- Cordless drill and assorted drill bits
- Masonite, plywood, 1/8" pressed fiberboard, cardboard or other suitable material to protect finished flooring
- Appropriate materials to cover and protect the home and its furnishings during installation

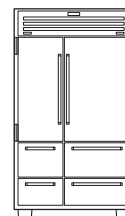

**Model 648PRO**

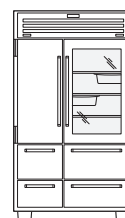

**Model 648PROG with Glass Door**

OVERALL DIMENSIONS

MODELS 648PRO AND 648PROG

Overall Width	48" (1219)
Overall Height	84" (2134)
Depth from behind Face Frame (standard installation)	23 <sup>7</sup> / <sub>8</sub> " (606)
Depth to front of Face Frame (flush installation)	25 <sup>7</sup> / <sub>8</sub> " (657)
Depth to Handles	30 <sup>5</sup> / <sub>32</sub> " (766)
Door Clearance (refrigerator)	28 <sup>3</sup> / <sub>4</sub> " (730)*
Door Clearance (freezer)	20 <sup>1</sup> / <sub>2</sub> " (521)*
Shipping Weight – 648PRO	885 lbs (401 kg)
Shipping Weight – 648PROG	900 lbs (408 kg)

\*Door clearance from front of face frame, add 2" (51) depth of face frame for standard installation.

Dimensions may vary by ± 1/8".

**IMPORTANT NOTE:** Model 648PROG features a glass door on the upper refrigerator compartment and Model 648PRO has a solid door. All overall dimensions and installation dimensions are identical for each of the PRO 48 units.

OVERALL DIMENSIONS

Front, side and top dimensions for Models 648PRO and 648PROG.

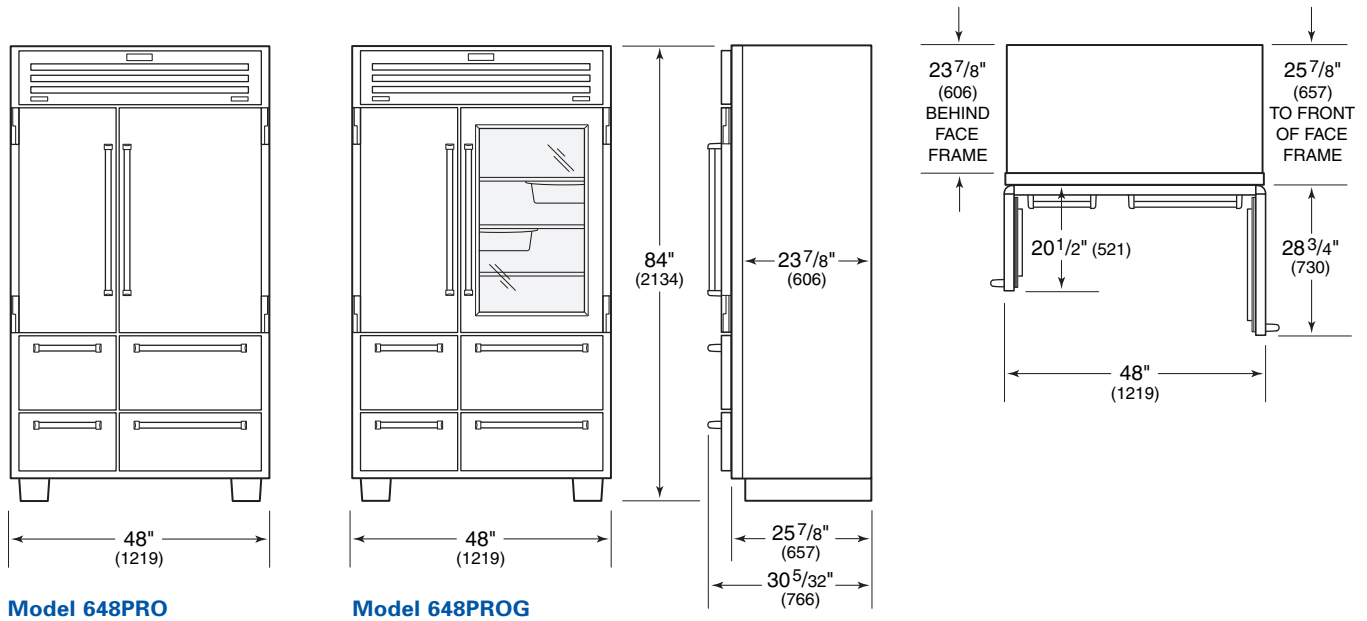

Dimensions in parentheses are in millimeters unless otherwise specified.



**INSTALLATION SPECIFICATIONS**

The PRO 48 can be used free-standing or installed as a standard or flush built-in application. For standard built-in installations, the face frame of the unit will extend 2" (51) beyond cabinetry. In flush built-in installations, the front of the face frame will be flush with surrounding cabinetry.

For built-in installations, make sure that the finished rough opening where the unit is to be installed is properly prepared. Refer to the Installation Specifications illustration to be sure that the rough opening dimensions, electrical service and plumbing are correct.

**IMPORTANT NOTE:** To operate properly, doors must be able to open a minimum of 90°. Use a filler strip in built-in corner installations to assure a 90° door opening. Allow enough clearance in front of the unit for full door swing.

**IMPORTANT NOTE:** Make sure that the floor under the unit is level with the surrounding finished floor and will be able to support the weight of the unit—885 lbs (401 kg) or 900 lbs (408 kg).

**INSTALLATION SPECIFICATIONS**

Standard or flush installation for Models 648PRO and 648PROG.

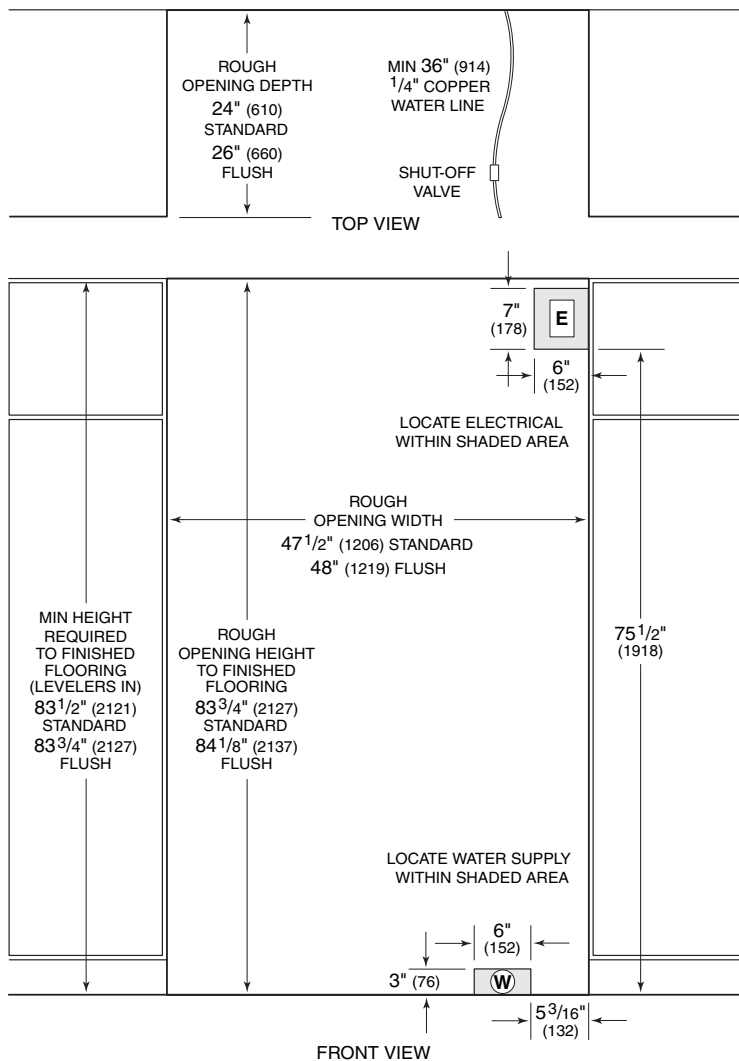

**MODELS 648PRO AND 648PROG**

Rough Opening Width (standard installation)	47 1/2" (1206)
Rough Opening Width (flush installation)	48" (1219)
Rough Opening Height (standard installation)	83 3/4" (2127)
Rough Opening Height (flush installation)	84 1/8" (2137)
Minimum Height Required (to finished flooring)	83 1/2" (2121)
Rough Opening Depth (standard installation)	24" (610)
Rough Opening Depth (flush installation)	26" (660)

*Dimensions are for finished rough openings.*



**ELECTRICAL** REQUIREMENTS

A 115 V AC, 60 Hz, 15 amp circuit breaker and electrical supply are required. A separate circuit, servicing only this appliance, is required. Locate the electrical outlet within the shaded area indicated in the Installation Specifications illustration on the previous page.

The PRO 48 is equipped with a power supply cord with a 3-prong grounding plug, which must be plugged into a mating 3-prong grounding-type wall receptacle. Follow the National Electrical Code and local codes and ordinances when installing the receptacle.

**IMPORTANT NOTE:** A ground fault circuit interrupter (GFCI) is not recommended and may cause interruption of operation.

**⚠ WARNING**  
**Do not use an extension cord or two prong adapter. Electrical ground is required on this appliance. Do not remove the power supply cord ground prong.**

**⚠ CAUTION**  
**The outlet must be checked by a qualified electrician to be sure that it is wired with the correct polarity. Verify that the outlet provides 115 volts and is properly grounded.**

**⚠ WARNING**  
**Always shut power off at the circuit breaker before performing any installation, service or maintenance.**

**PLUMBING** REQUIREMENTS

The PRO 48 has an automatic ice maker with an integrated water filtration system. This system operates on water pressure between 35 psi (2.4 bar) and 120 psi (8.3 bar). If the water filtration system is bypassed, a water pressure between 20 psi (1.4 bar) and 120 psi (8.3 bar) must be maintained. Refer to Water Filter Bypass Mode on page 7.

Rough in the cold water supply line using 1/4" OD copper line. The water line should be routed up through the floor within 1/2" (13) from the back wall and no higher than 3" (76) off the floor. If you have to come through the wall, make sure the water line is no more than 3" (76) from the floor.

Regardless of the routing, allow 3' (.9 m) of excess copper tubing to remain outside the wall or floor for easy connection to the unit. Locate the water supply line within the shaded area indicated in the Installation Specifications illustration on the previous page.

Use an easily accessible shut-off valve between the water supply and the unit. Do not use self-piercing valves. A saddle valve kit (part #4200880) is available from your Sub-Zero dealer.

It is not recommended that the ice maker be connected to a softened water supply. Water softener chemicals, such as salt from a malfunctioning softener, can damage the ice maker and lead to poor ice quality. If a softened water supply cannot be avoided, be sure that the water softener is well maintained and operating properly.

**IMPORTANT NOTE:** Do not use with water that is microbiologically unsafe or of unknown water quality without adequate disinfection before or after the system. Systems certified for cyst reduction may be used on disinfected waters that may contain filterable cysts.

**IMPORTANT NOTE:** All installations must meet local plumbing code requirements.

**IMPORTANT NOTE:** A reverse osmosis system can be used, provided there is constant water pressure of 20 psi (1.4 bar) to 120 psi (8.3 bar) supplied to the unit at all times. In this application, the integrated water filtration system must be set to bypass mode.

UNPACKING THE PRO 48

WATER FILTER BYPASS MODE

If you choose not to use the water filtration system, the system can be placed in water filter bypass mode by removing the water filter cartridge. In this mode, the water supplied to the ice maker will not be filtered and the electronically controlled water filter monitor will be deactivated.

Lift the grille to access the water filter cartridge. To lift the grille, pull out on the bottom edge of the grille and tilt the grille frame forward.

Slowly rotate the water filter cartridge 1/4 turn counterclockwise to disengage. Gently twist until the cartridge is free from the base, DO NOT pull. Refer to the illustration below. There will be water in the filter cartridge, so it is normal for a small amount of water to spill out.

The water filtration system automatically goes into bypass mode when the filter cartridge is removed.

Uncrate the unit and inspect for any damages. Remove the wood base and discard the shipping bolts and brackets that hold the wood base to the bottom of the unit. Tip the unit slightly to each side to remove styrene pads under the base. Remove and discard all packing materials.

**IMPORTANT NOTE:** Do not discard the kick-plate, anti-tip bracket and hardware or corner protectors. These items will be needed for installation.

REMOVING THE GRILLE

In order to prevent damage to the grille, the top grille assembly should be removed prior to moving the unit.

To remove the grille assembly, pull out on the bottom edge of the grille and tilt the grille frame forward. Disconnect the low-voltage cable which connects the exterior temperature displays on the grille to the display module, and cut the two white cable ties which attach the network cable to the right grille support. These cables ties should be replaced once the unit is properly installed with the extra cable ties provided in this package. Remove the three 7/16" bolts from base of the grille. Remove the screw from the upper grille area to remove the grille assembly. Refer to the illustration below.

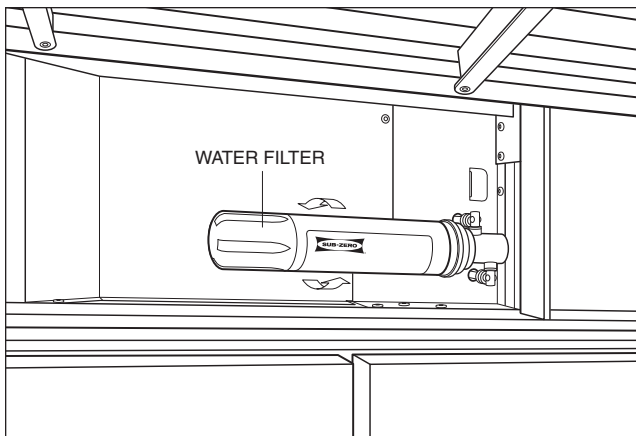

Water filter

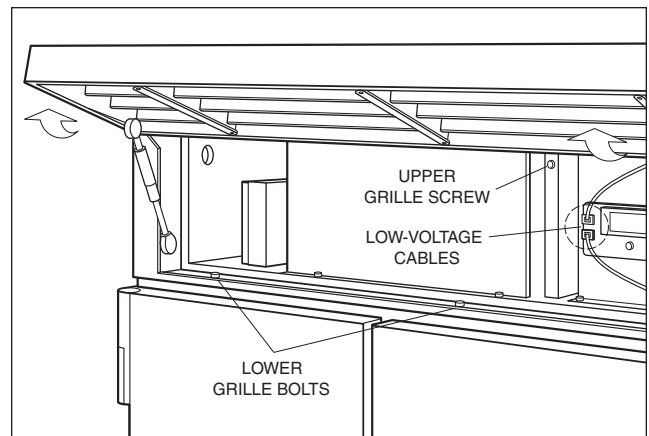

Removing the grille

Dimensions in parentheses are in millimeters unless otherwise specified.

ANTI-TIP BRACKET INSTALLATION

**⚠ WARNING**

To prevent the PRO 48 from tipping forward and provide a stable installation, the unit must be secured in place with the anti-tip bracket shipped with the unit.

**IMPORTANT NOTE:** Placement of the anti-tip bracket is critical to a stable installation. It must be installed exactly 26" (660) from the front of the face frame of the unit to the back of the anti-tip bracket. Also, the centering line on the lower flange of the anti-tip bracket must be centered in the rough opening. Failure to properly position the anti-tip bracket will prevent it from engaging the unit. Be sure that the anti-tip bracket is installed on a solid base. Refer to the illustrations below.

**IMPORTANT NOTE:** For a stable installation, be sure to use all anti-tip bracket hardware as instructed for wood or concrete floors to properly secure the bracket.

WOOD FLOOR APPLICATIONS

Use the twelve #12 x 2 1/2" wood screws and the twelve #12 flat washers provided. Drill pilot holes 3/16" (5) diameter maximum and be sure that the screws penetrate through the flooring material and into the wall plate a minimum of 3/4" (19). Be sure that the screws hold tight. Refer to the illustration below.

**IMPORTANT NOTE:** If the wood screws do not hit a wall stud in any of the upper holes on the anti-tip bracket, use the provided #8-18 x 1 1/4" wood screw, #12 flat washer and nylon zip-it wall anchor in its place.

**IMPORTANT NOTE:** In some installations the subflooring or finished floor may necessitate angling the wood screws used to fasten the anti-tip bracket to the back wall. Refer to the illustration below.

**⚠ WARNING**

Make sure that there are no electrical wires or plumbing in the area which the screws could penetrate.

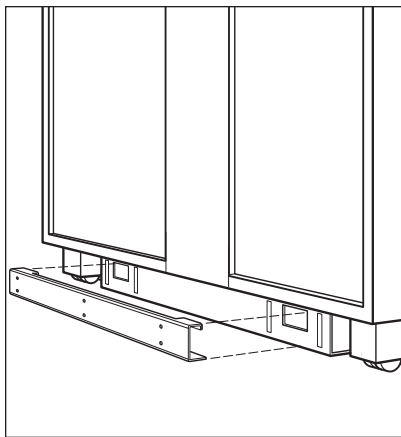

Anti-tip bracket alignment

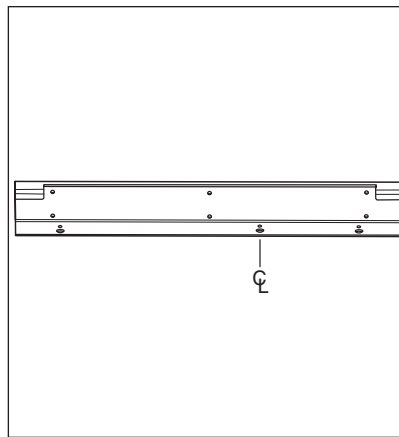

Anti-tip bracket centerline

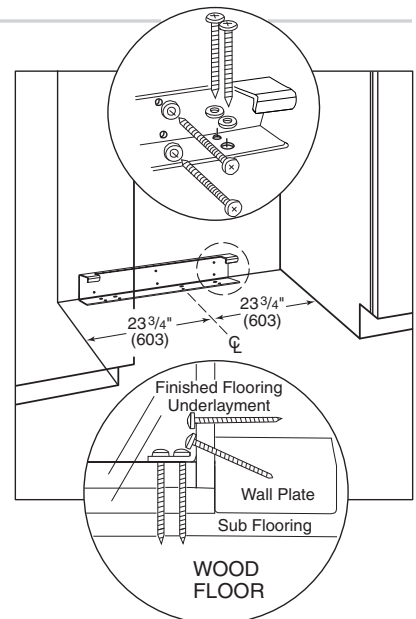

Wood floors

CONCRETE FLOOR APPLICATIONS

Use the three 3/8" x 3 3/4" concrete wedge anchors, six #12 x 2 1/2" wood screws and six #12 flat washers provided. Be sure that the anchors and screws hold tight. Refer to the illustration below.

**IMPORTANT NOTE:** If the wood screws do not hit a wall stud in any of the upper holes on the anti-tip bracket, use the provided #8-18 x 1 1/4" wood screw, #12 flat washer and nylon zip-it wall anchor in its place.

**IMPORTANT NOTE:** In some installations the subflooring or finished floor may necessitate angling the wood screws used to fasten the anti-tip bracket to the back wall. Refer to the illustration below.

**⚠ WARNING**

Make sure that there are no electrical wires or plumbing in the area which the screws could penetrate.

INSTALL CONCRETE WEDGE ANCHORS

- 1) Drill a 3/8" (10) diameter hole any depth exceeding the minimum embedment. Clean the hole or continue drilling additional depth to accommodate drill fines. Use a carbide drill bit manufactured within ANSI B94.12-77.
- 2) Assemble the washer and nut flush with the end of anchor to protect threads. Drive the anchor through the material to be fastened until the washer is flush with the surface material.
- 3) Expand the anchor by tightening the nut 3-5 turns past hand-tight position or to 25 foot-pounds of torque.

**⚠ CAUTION**

Always wear safety glasses and use other necessary protective devices or apparel when installing or working with anchors.

Anchors are not recommended for use in lightweight masonry material such as block or brick, or for use in new concrete which has not had sufficient time to cure. The use of core drills is not recommended to drill holes for the anchors.

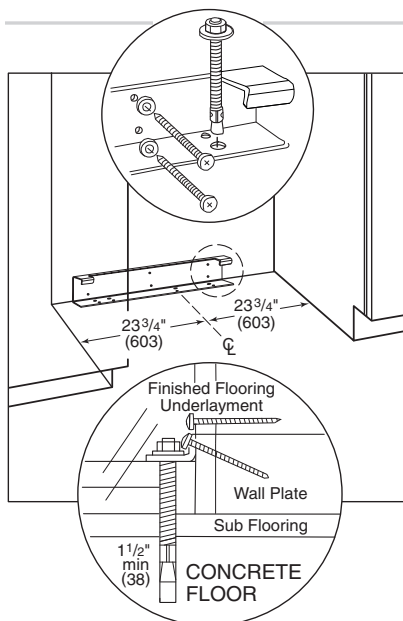

ANTI-TIP HARDWARE INCLUDED

12	#12 x 2 1/2" PN HD Wood Screw	6201190
3	3/8" x 3 3/4" Trubolt Anchor	6110620
12	#12 flat washer	6240040
3	#8-18 x 1 1/4" AB PH HD Screw	6201520
3	Nylon Zip-It Wall Anchor	6160390

Concrete floors

Dimensions in parentheses are in millimeters unless otherwise specified.

MOVING THE PRO 48

After you've completed the steps for unpacking the PRO 48 and have removed the grille and installed the anti-tip bracket, carefully move the unit onto an appliance dolly. When securing the unit on the appliance dolly, use the corner protectors retained from the packaging under the strapping to avoid damage to the stainless steel exterior. Also, secure the doors and drawers closed with the strapping. Refer to the illustration below for proper placement of the appliance dolly.

**IMPORTANT NOTE:** Protect the surrounding finished flooring with masonite, plywood, 1/8" (3) pressed fiberboard or other suitable material before moving the unit across it.

Carefully move the PRO 48 into place near the rough opening and move it off of the appliance dolly. The PRO 48 is equipped with rollers, so it can be moved into position more easily.

**⚠ WARNING**

**The PRO 48 is very heavy – 885 lbs (401 kg) or 900 lbs (408 kg) – be sure to have adequate manpower when moving and positioning the unit. Secure doors and drawers closed before moving the unit.**

Retract the front leveling legs all the way up to allow the unit to be moved into position more easily. You will extend the front leveling legs down and adjust once the unit is in position.

**IMPORTANT NOTE:** The rear levelers must be in their lowest position in order to push the unit back into the rough opening. Therefore, leveling cannot be completed until the unit is in position.

Shut off power to the wall outlet. Plug the power supply cord into the 15 amp grounded outlet and roll the unit into position. Be sure that the anti-tip bracket is properly engaged.

**IMPORTANT NOTE:** If for any reason the unit has been laid on its back or side, you must allow the unit to stand upright for a minimum of 24 hours before connecting power.

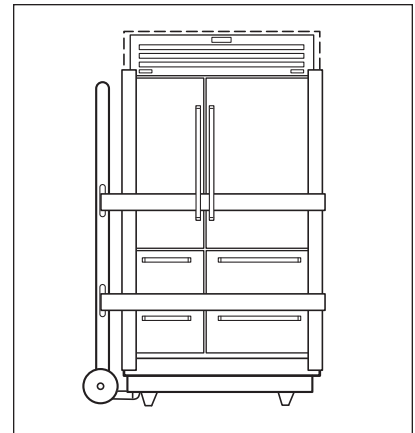

Proper placement of appliance dolly

### WATER LINE CONNECTION

Approximately 3' (.9 m) of 1/4" plastic tubing is connected to the ice maker with a preassembled 1/4" compression connection at the end. This tubing is located under the unit.

The water line fitting connection kit, provided with the unit, contains a 1/4" compression sleeve and a 1/4" compression nut for connection to the household water line. Place the compression nut and sleeve on the water line and fasten to the connection at the end of the tubing under the unit. Do not over tighten. Check all water line fittings for leaks. Make sure that the drain pan can be installed or removed without any water line interference.

**IMPORTANT NOTE:** Be sure to purge the water line prior to final connection to the unit. This will remove any debris that may be present in the tubing from installing the new water line.

**IMPORTANT NOTE:** If the house has a reverse osmosis system, the integrated water filtration system must be placed in bypass mode. Refer to page 7 for instructions.

**IMPORTANT NOTE:** Let your customer know that the ice maker will not produce ice immediately, and that the first bucket of ice produced should be discarded. Allow 48 hours of ice production, before discarding the first bucket of ice.

### LEVELING THE UNIT

Once the unit is in position, extend the front leveling legs down by turning the legs counterclockwise and adjust the height. The rear height adjustment can be made from the front of the base. Use a 5/16" socket to adjust the rear rollers. Turn the 5/16" hex bolt clockwise to raise the unit or counterclockwise to lower it.

When the unit is leveled properly, or squared off, door and/or drawer adjustments are less likely to be necessary. Refer to the illustration below for location of the rear roller base adjustment.

**IMPORTANT NOTE:** Be sure to reference leveling of the unit to the floor and not to surrounding cabinetry. This could affect the operation of the unit, such as doors not closing properly.

### INSTALL THE KICKPLATE

To install, screw the kickplate to brackets attached to the inside surface of each roller base.

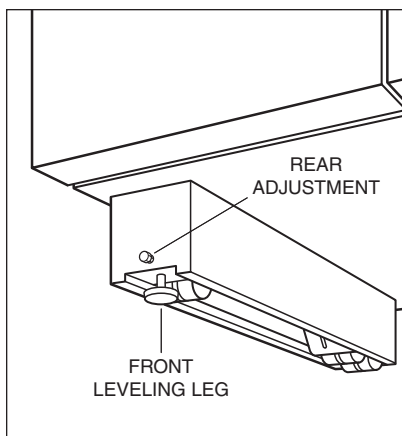

#### Rear roller base adjustment

Dimensions in parentheses are in millimeters unless otherwise specified.

**DOOR ADJUSTMENT**

Check to make sure that both doors are properly adjusted. If not, adjustments can be made to the cabinet and door hinges.

**IMPORTANT NOTE:** Be sure the unit is properly leveled before doing any cabinet or door hinge adjustment.

**CABINET HINGE ADJUSTMENT**

The door must be removed to adjust cabinet hinges. To remove the door, lift up the vent portion of the top grille, open the door to about 45° and lift the door off the cabinet hinges. Remove the hinge pins.

Loosen the two cabinet hinge fasteners  $\frac{1}{4}$  to  $\frac{1}{2}$  turn. Refer to the illustration below. Reinstall hinge pins and door. Open the door and using the Allen wrench provided, turn the adjustment screw to relocate the cabinet hinge. Close the door and check alignment. Repeat these steps until the door is properly aligned.

Remove the door and hinge pins again and tighten the two cabinet hinge fasteners. Reinstall hinge pins and door and close the vent portion of the top grille.

**⚠ CAUTION**

**Hinge pins may stick in the door rather than the cabinet hinge and may fall out of the door after a few seconds, which could cause damage to floors or injury.**

**DOOR HINGE ADJUSTMENT**

The door must be removed to adjust door hinges. To remove the door, lift up the vent portion of the top grille, open the door to about 45° and lift the door off the cabinet hinges. Remove the hinge pins.

Loosen the two door hinge fasteners, slide hinge to the desired position and retighten the fasteners. Refer to the illustrations below. Reinstall hinge pins and door. Check alignment and door seal. Close the vent portion of the top grille.

**⚠ CAUTION**

**When adjusting cabinet and door hinges, it is important to keep the hinges parallel to the face of the door and side of the cabinet. The door switch will not function if the hinges are excessively misaligned, which will cause the lights to stay on and the fan to not operate. This will result in elevated cabinet temperatures. After hinge adjustments are made, check that the door switch is functioning properly.**

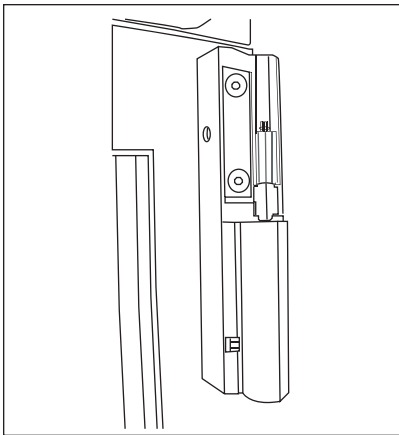

**Cabinet hinge adjustment**

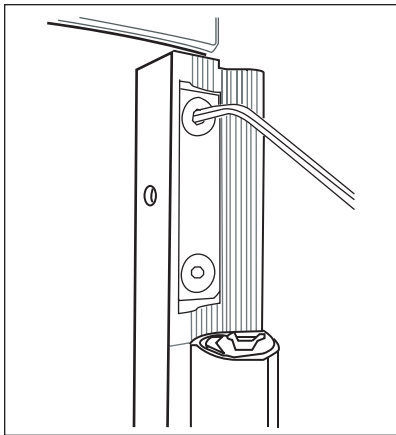

**Door hinge adjustment**

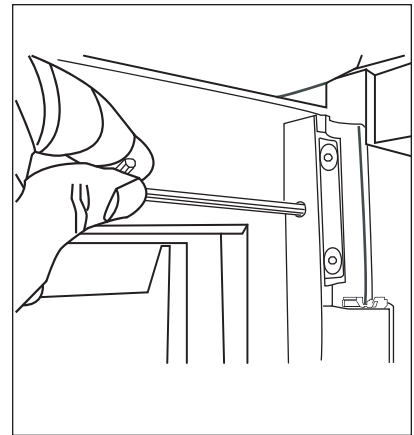

**Door hinge adjustment**

**DRAWER ADJUSTMENT**

Check to make sure that all drawers are properly adjusted. If not, vertical and horizontal adjustments can be made to the drawers.

**VERTICAL ADJUSTMENT**

The drawer must be removed to make vertical adjustments. To remove the drawer, pull the drawer all the way out until it stops, lift up evenly on both sides of the drawer front and pull out.

Loosen the three drawer slide mounting fasteners. Using a  $\frac{7}{16}$ " open-end wrench, turn the adjustment fastener to the desired position and retighten the fasteners. Refer to the illustration below.

To reinstall the drawer, raise the front of the drawer and place onto the drawer slide tracks. Be sure to engage the front of the drawer slide with the drawer assembly.

Check alignment of the automatic drawer closer. If the closer catch does not align with the closer pin, adjust the position of the auto-close mechanism.

**HORIZONTAL ADJUSTMENT**

The drawer must be removed to make horizontal adjustments. To remove the drawer, pull the drawer all the way out until it stops, lift up evenly on both sides of the drawer front and pull out.

Loosen the screws on the front two slides, then move adjustments blocks to the desired position and retighten the screws. Refer to the illustration below.

Release the rear adjustment block by disengaging the snaps. Move the block forward to shift drawer to the right and back to shift drawer to the left. Each position will move the drawer .030" (.8). Refer to the illustration below. Snap the block over the pins located on the rear adjuster. Both sides should be moved in the same direction.

To reinstall the drawer, raise the front of the drawer and place onto the drawer slide tracks. Be sure to engage the front of the drawer slide with the drawer assembly.

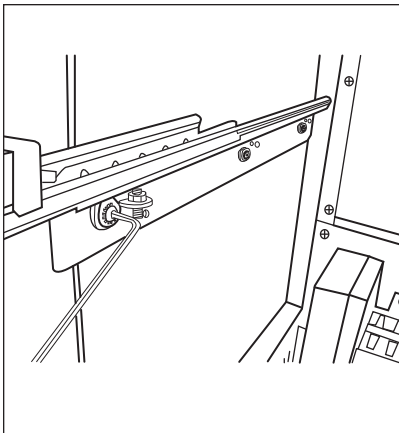

**Vertical drawer adjustment**

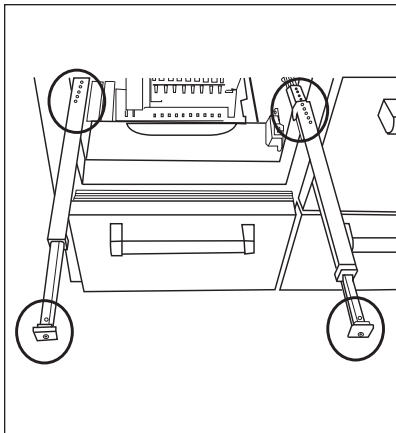

**Horizontal drawer adjustment**

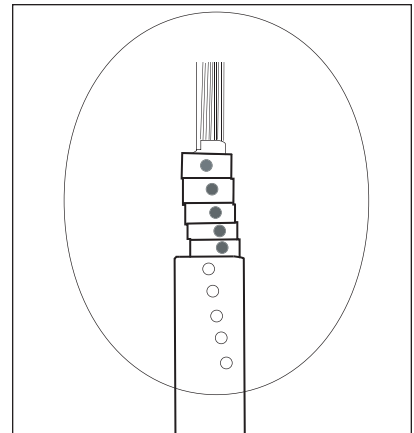

**Horizontal drawer adjustment**

Dimensions in parentheses are in millimeters unless otherwise specified.



SIDE AND TOP **PANELS**

Accessory stainless steel side and top panels are available through your Sub-Zero dealer. Installation instructions are included with the panels. To obtain local dealer information, visit the Locator section of our website, [subzero.com](http://subzero.com).

90 DEGREE **DOOR STOP**

The doors of PRO 48 models open to 135 degrees. An optional 90° door stop kit is available through your Sub-Zero dealer. To obtain local dealer information, visit the Locator section of our website, [subzero.com](http://subzero.com).

**INSTALLATION CHECKLIST**

The importance of the installation of the Sub-Zero PRO 48 cannot be overemphasized. Proper installation is the responsibility of the selling dealer or installer.

**IMPORTANT NOTE:** To ensure a safe and proper installation, the following checklist should be completed by the installer to ensure that no part of the installation has been overlooked.

Any questions or problems about the installation should be directed to your Sub-Zero dealer or the Sub-Zero Customer Service Department at 800-222-7820. You may also check the service center locator on our website, [subzero.com](http://subzero.com).

**INSTALLATION CHECKLIST**

- Has the packing material been removed?
- Has any damage to stainless steel been noted?
- Turn the unit on. Is it operating properly? If not, is the unit plugged in? Is the control button turned on?
- Is the water supply line connected and not leaking?
- Has anti-tip bracket been installed securely?
- Is the unit leveled properly on a solid, level floor?
- Has the drain pan been installed properly?
- Is the kickplate installed?
- Are the grille screws back in position?
- Are the doors and drawers adjusted for proper operation, sealing and alignment? Does either door need a 90° door stop?
- Does your customer understand the unit's operation?
- Has the water filter cartridge been removed (only for homes with a reverse osmosis system)?
- Is the water supply turned on and ice maker switch on?
- Have you given your customer the warranty package?
- Have any installation or service problems been noted on the product registration card? Has the registration card been mailed in?

Dimensions in parentheses are in millimeters unless otherwise specified.



## SERVICE INFORMATION

If you need service, be sure to have the model and serial number when you call. You'll find these numbers on the model and serial number plate located on the left side of the top freezer drawer compartment.

Call your Sub-Zero authorized service center; contact your dealer or the Sub-Zero Customer Service Department, P. O. Box 44130, Madison, WI 53744-4130 or call 800-222-7820. You may also check the service center locator on our website, [subzero.com](http://subzero.com).

### **⚠ WARNING**

**If you are storing or disposing of your old refrigerator or freezer, please do it safely. Remove the doors or tightly secure the doors closed. Child entrapment accidents can be tragic.**

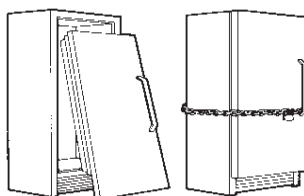

## CONTACT INFORMATION

**Sub-Zero  
Customer Service:  
800-222-7820**

**Website:  
[subzero.com](http://subzero.com)**

**The information and images in this book are the copyright property of Sub-Zero Freezer Company, Inc. Neither this book nor any information or images contained herein may be copied or used in whole or in part without the express written permission of Sub-Zero Freezer Company, Inc.**

**©Sub-Zero Freezer Company, Inc. all rights reserved.**

**PRO  
48**

SUB-ZERO FREEZER COMPANY, INC. P. O. BOX 44130 MADISON, WI 53744-4130 800-222-7820 SUBZERO.COM

