

PRO 48

PRO  
48

USE & CARE INFORMATION





CONTENTS

Introducing the Sub-Zero PRO 48	3
Sub-Zero PRO 48 Features	4
Sub-Zero PRO 48 Use & Care	6
Keeping Food at Its Best	15
Food Storage Recommendations	19
Water Filtration System Performance Data	25
State of California Certification	26
Troubleshooting Guide	27
Service Information	30
Sub-Zero Warranty	31

As you read this Use & Care Information, take particular note of the CAUTION and WARNING symbols when they appear. This information is important for safe and efficient use of the Sub-Zero equipment.

**⚠ CAUTION**

signals a situation where minor injury or product damage may occur if you do not follow instructions.

**⚠ WARNING**

states a hazard that may cause serious injury or death if precautions are not followed.

In addition, this Use & Care Information may signal an IMPORTANT NOTE which highlights information that is especially important.



## THANK YOU

Thank you for purchasing your new Sub-Zero PRO 48 side-by-side refrigerator/freezer. With Sub-Zero, you can rely on a 60-year tradition of quality and reliability.

Built in to cabinetry or free-standing, the PRO 48 is just the latest example of Sub-Zero pushing food preservation to new heights. And of course, the PRO 48 still meets rigorous Department of Energy standards for residential use. Featuring a glass door on Model 648PROG or top-to-bottom stainless steel on Model 648PRO. The PRO 48 brings together the latest technology and finest features in home refrigeration to give you the freshest food possible.

Your Sub-Zero is protected by a warranty that is one of the finest in the industry. Take a moment to read the warranty statement on page 31 and refer to it should service become necessary.

This Use & Care Information book will answer most of your questions about the features, operation and maintenance of your PRO 48 unit. If you have questions that are not addressed here, call 800-222-7820, e-mail us at [customerservice@subzero.com](mailto:customerservice@subzero.com) or visit our website, [subzero.com](http://subzero.com).

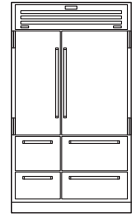

**Model 648PRO**

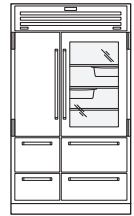

**Model 648PROG  
with Glass Door**



**PRO 48** FEATURES

WARRANTY

**Sub-Zero products are covered by a two, five and twelve year residential warranty (exclusions apply). See warranty details at the end of this guide.**

- Can be built in or, with the free-standing accessory kit, used in a free-standing application
- Dual refrigeration—two compressors and three evaporators keep foods fresher longer and prevent odor transfer
- Exterior temperature display with easy-to-read digital readouts, accurate within one degree of your preset temperatures
- Microprocessor and interior control panel with up-front touch controls monitor pattern-sensing defrost and automatic service alerts
- Holiday mode—power down one or both sides for extended periods or just the weekend
- Slide-out stainless steel bins—two versatile, removable bins hold small items and fit neatly under any shelf
- Crisper drawer is a touch-and-glide crisper with a tight-seal glass lid that gives vegetables generous humidity
- Drawers with dividers help you enjoy full access to food with adjustable, removable, and interchangeable drawer dividers
- Automatic ice maker lets you retrieve filtered ice from a stainless steel bucket
- Shelves are cantilevered and spill-proof, with stainless steel trim (refrigerator); adjustable, removable and 100% stainless steel (freezer)
- Auto-close system with an advanced hinge design lets doors finish closing easily and automatically
- Alarm with an audible beep lets you know when doors or drawers are left ajar
- Water filter is easy to replace and is just behind the pop-up grille, for ice as pure as it is fresh
- Easy-access grille pops up with a simple pull (no tools needed) to reveal the water filter and condenser for cleaning
- Stainless steel construction and classic finish (inside and out) for professional strength and beauty
- Advanced lighting—top LED lights bathe upper compartments in a soft glow; on the refrigerator side, channeled sidewall LEDs can even serve as door area night lights (night light option available on Model 648PROG only)
- Triple-pane, UV-resistant glass—specially treated glass offers convenient visibility while filtering harmful rays and saving energy (Model 648PROG only)
- For installations at or above 5,000' (1524 m) in elevation, high altitude glass is available as a special order
- Certified by Star-K to meet religious regulations
- UL approved for US and Canada

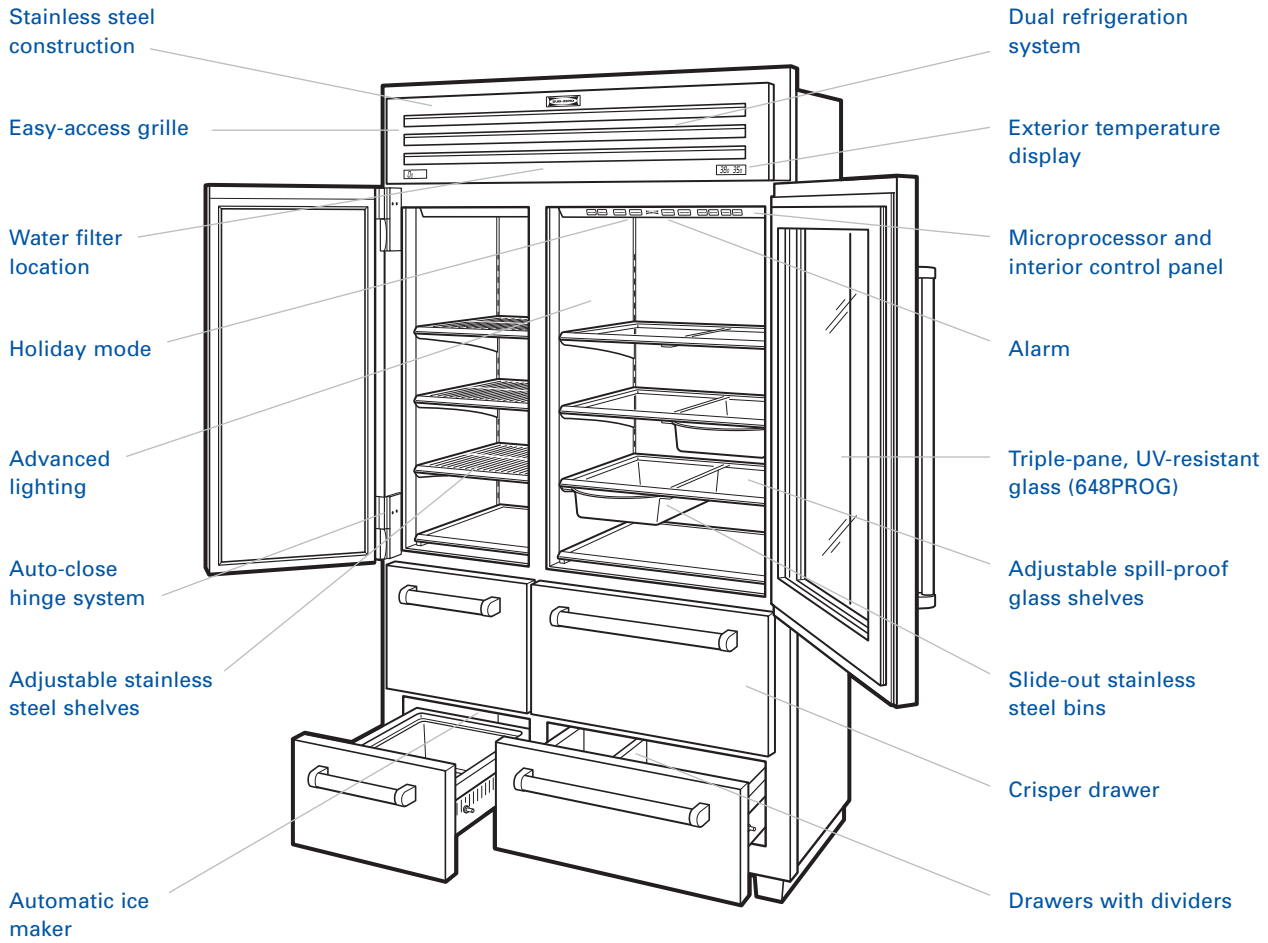

Model 648PROG with glass door shown



This appliance is certified by Star-K to meet strict religious regulations in conjunction with specific instructions found on [www.star-k.org](http://www.star-k.org).

**DUAL REFRIGERATION SYSTEM**

The PRO 48 continues the Sub-Zero tradition of superior quality and reliability. Sub-Zero pioneered the development of our exclusive dual refrigeration systems, giving you optimum fresh and frozen food storage in ideal self-contained compartments. Both refrigerator and freezer maintain accurate, consistent temperatures. Dual refrigeration keeps your food fresh longer than any other system available.

With dual refrigeration, the freezer maintains a consistent temperature within one degree of the temperature you set within our range of -5°F (-20°C) to +5°F (-15°C), without unwanted moisture and odor from the refrigerator. Similarly, you can adjust the refrigerator temperature within a range of 34°F (1°C) to 45°F (7°C), for proper humidity levels tailored for longer food life expectancy.

Dual refrigeration also means there is no transfer of fresh food odors to frozen food or ice. The PRO 48 system does not freeze the moisture out of the air in the fresh food compartments.

The Sub-Zero dual refrigeration system is more energy efficient than standard single refrigeration systems. When the refrigerator is used frequently during the day, it does not require the freezer to circulate its very cold, dry air to the refrigerator. Instead, the refrigerator uses moist air to keep fresh foods fresh and energy use minimal.

**ELECTRONIC CONTROL SYSTEM**

The electronic control system of the PRO 48 monitors and accurately displays compartment temperatures within one degree of your pre-set temperatures. It also monitors the operation of the unit and lets you know if there is a problem. The interior control panel located at the top of the refrigerator door compartment has key pads to set temperatures and control functions of the electronic control system.

**TEMPERATURE CONTROL**

Your new PRO 48 was thoroughly inspected and tested before it was shipped from the Sub-Zero factory. Temperatures are preset at 38°F (3°C) in refrigerator compartments and 0°F (-18°C) in the freezer compartments.

There are three sets of **WARMER** and **COLDER** key pads on the interior control panel, two for the refrigerator compartments (upper door and lower drawers) and one for the freezer compartments. To adjust the temperature in any of the three compartments, depress the **WARMER** or **COLDER** key pad for that compartment. Digital temperatures for each of the three compartments are displayed in the exterior temperature display.

Temperature ranges are -5°F (-20°C) to +5°F (-15°C) in the freezer sections and 34°F (1°C) to 45°F (7°C) in the refrigerator sections. It is normal for temperatures to fluctuate slightly, depending on external influences such as an open door, the degree of humidity and room temperature.

**IMPORTANT NOTE:** Always allow 24 hours for compartments to reach the temperature you set.

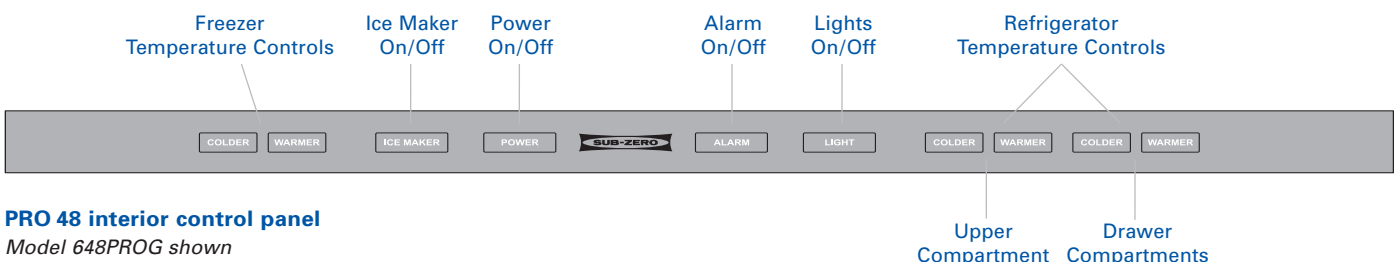

**PRO 48 interior control panel**  
Model 648PROG shown

## EXTERIOR TEMPERATURE DISPLAY

Electronic control system functions, such as digital temperatures and service indicators, are displayed in two exterior temperature displays located on the grille. The display in the lower left area of the grille shows the temperature and indicators for freezer compartments, and the display in the lower right gives readouts for refrigerator compartments.

## POWER ON/OFF

The **POWER** key pad on the control panel will shut off all electrical power to the unit. When the power is off, the OFF indicator light will be visible in the exterior temperature display. Using the **POWER** key pad means you do not have to shut off power at the circuit breaker or unplug the unit. The **POWER** key pad can be used for extended vacations.

It is possible to shut off power to one compartment of the PRO 48 for an extended period without affecting operation of the other compartments.

First, turn the unit off by depressing the **POWER** key pad. Then push and hold the **WARMER** key pad of the compartment you wish to shut down. Depress the **POWER** key pad to turn the unit back on. The disabled zone will be indicated with "--" in the exterior temperature display. Repeat the process to resume power to the compartment.

### **⚠ WARNING**

**Be sure to shut off power to the unit at the circuit breaker during service.**



**PRO 48 exterior temperature display**

## ALARM FEATURE

The PRO 48 has an alarm feature that lets you know with an audible beep if a door or drawer is left ajar. The alarm will sound after 30 seconds if a door or drawer is left open and will stop once the door or drawer is closed. This alarm can be disabled for cleaning or restocking by depressing the **ALARM** key pad on the control panel.

## ICE MAKER ON/OFF

The **ICE MAKER** key pad on the control panel switches power to the ice maker system on or off. Use the **ICE MAKER** key pad to shut down ice maker operation during extended vacations. The ice bucket icon will be visible in the exterior temperature display if the ice maker system is on.

## VISUAL SERVICE DISPLAY

The electronic control system monitors compartment and component temperatures as well as the ice maker system. If there is a temperature or ice maker problem, you will be alerted by a flashing SERVICE indicator light in the exterior temperature display. This same SERVICE light will also flash if the condenser needs cleaning.

## SABBATH MODE (STAR-K)

The PRO 48 features Sabbath Mode for certain religious observances where lights and the ice maker need to be turned off.

To initiate Sabbath Mode while the unit is on, press the **POWER** key pad on the control panel so that OFF is visible in the exterior temperature display. Then press and hold the **POWER** key pad for 10 seconds. This will turn the unit back on with lights and ice maker disabled. There will be four short beeps, indicating that the Sabbath Mode has been set. To return the unit to normal operation, press and release the **POWER** key pad.

If you have questions about Star-K compliance, visit [www.star-k.org](http://www.star-k.org).

**REFRIGERATOR STORAGE**

**ADJUSTABLE GLASS SHELVES**

The adjustable glass shelves of the PRO 48 upper refrigerator compartment are cantilevered and spill proof with stainless steel trim.

To remove a shelf, tilt the shelf up at the front, then lift it up and out of the tracks on the rear wall of the refrigerator. To replace a shelf, insert in the tracks with the front of the shelf raised slightly. As you push the shelf in, lower the front of the shelf until it locks into position. Refer to the illustration of the adjustable glass shelves below.

**IMPORTANT NOTE:** Always be careful handling glass shelves to prevent breaking the glass or scratching the interior.

**CRISPER LID ASSEMBLY**

The PRO 48 upper refrigerator drawer features a crisper lid to provide higher humidity in the drawer compartment. This assembly allows for easy access to the compartment and has a clear-view window for visibility of stored vegetables.

To remove the crisper lid assembly, pull the upper refrigerator drawer all the way out, raise the front edge of the crisper lid assembly up and pull out from the back. Refer to the illustration of the crisper lid below.

**REFRIGERATOR DRAWER DIVIDERS**

The PRO 48 refrigerator storage drawers give you full access to food with adjustable and removable dividers. The dividers are interchangeable between the upper and lower refrigerator drawer. Two long dividers run the full depth of the drawer, with shorter dividers that connect to the long dividers to compartmentalize the drawer.

To remove the short dividers, lift up and out of position from supports on the long dividers and sides of the drawer. The long dividers can also be removed by lifting up and out of position from drawer support tabs. Refer to the illustration of the storage drawer below.

**ADJUSTABLE SLIDE-OUT BINS**

The PRO 48 features two versatile, adjustable stainless steel slide-out bins that fit neatly under any refrigerator compartment shelf. The glass shelves have integrated rails that make it possible to position the slide-out bins in a variety of locations.

To remove the slide-out bin, simply pull the handle portion of the bin forward until it stops, lift it up and out of the rails mounted below the glass shelf. Refer to the illustration of the adjustable slide-out bin below.

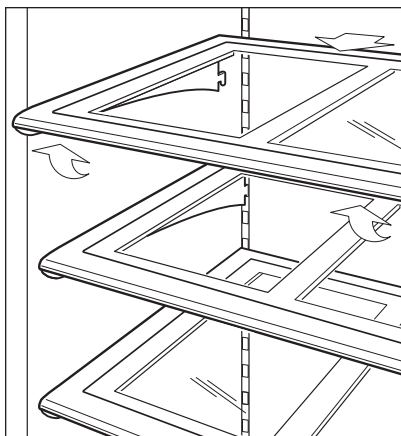

**Adjustable glass shelves**

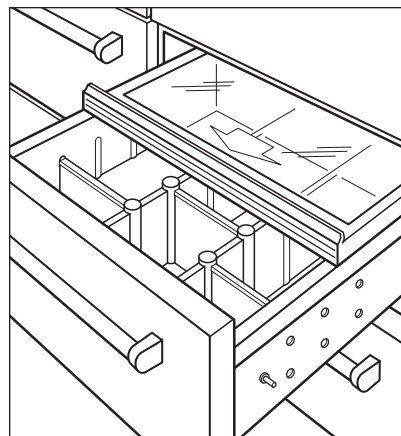

**Storage drawer with crisper lid**

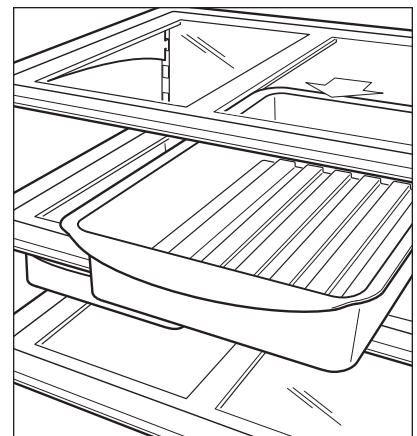

**Adjustable slide-out bin**

## FREEZER STORAGE

### ADJUSTABLE SHELVES

The adjustable shelves of the PRO 48 upper freezer compartment are cantilevered and 100% stainless steel.

The freezer shelves are repositioned the same way as the glass shelves in the refrigerator compartment. To remove or adjust the freezer shelves, first tilt the shelf up at the front, then lift it up and out of the tracks on the rear wall of the freezer.

To replace a shelf, insert in the tracks on the rear wall of the freezer with the front of the shelf raised slightly. As you push the shelf in, lower the front of the shelf until it locks into position.

### ICE BUCKET REMOVAL

The automatic ice maker and stainless steel ice bucket are located in the lower freezer drawer.

To remove the ice bucket, pull the freezer drawer out until it stops, lift the ice bucket up and out of the drawer. The entire lower freezer drawer can now be used for more ice storage if necessary.

## STORAGE DRAWER REMOVAL

The refrigerator and freezer storage drawers are removable for cleaning. The drawers have an automatic stop built in to prevent drawers from coming all the way out of the unit.

To remove, pull the drawer all the way out until it stops, lift up evenly on both sides of the drawer front and pull out. To reinstall, raise the front of the drawer and place onto the drawer slide tracks. Be sure to engage the front of the drawer slide with the drawer assembly. Refer to the illustration of the storage drawer removal below.

**IMPORTANT NOTE:** To reduce the weight of the drawer, be sure to unload the contents before removing the drawer.

### ⚠ CAUTION

**Storage drawers are heavy. Be sure to keep your feet clear as you remove the drawer.**

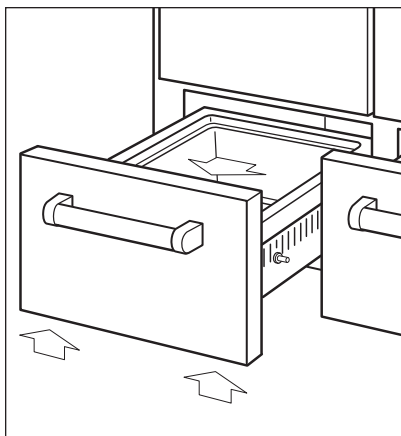

**Storage drawer removal**



## **WATER FILTRATION SYSTEM**

The PRO 48 features a water filtration system that supplies filtered water to the ice maker to produce great-tasting ice. The water filter has been factory installed behind the grille assembly.

It is important that the operation, maintenance and filter replacement requirements be carried out as scheduled. See Water Filter Cartridge Monitor.

**IMPORTANT NOTE:** If the unit has been turned off or the ice maker disabled for one month or longer, the water filter cartridge should be replaced once the unit and ice maker are back in operation.

**IMPORTANT NOTE:** Do not use with water that is microbiologically unsafe or of unknown water quality without adequate disinfection before or after the system. Systems certified for cyst reduction may be used on disinfected waters that may contain filterable cysts.

Refer to the Performance Data on page 25 for additional information regarding the water filtration system.

## **WATER FILTER CARTRIDGE MONITOR**

The water filter cartridge is designed to last for up to one year of continuous use of the ice maker. The electronic control system monitors the life of the water filter cartridge and indicates when it needs to be replaced. An indicator that reads "REPLACE FILTER" will be visible in the left side exterior temperature display. Follow steps to replace the water filter cartridge on the following page.

Once the filter cartridge has been replaced, the control automatically resets the water filter life monitor and the "REPLACE FILTER" indicator will no longer be displayed.

Although it is designed to last for up to one year of use, the actual life of the filter cartridge may vary with water supply conditions. Therefore, it is recommended that the filter cartridge be replaced when the "REPLACE FILTER" indicator is displayed or if the ice cubes become hollow or smaller.

**IMPORTANT NOTE:** The warranty for the water filter cartridge supplied with the unit only covers defects in materials or workmanship and not replacement due to normal use.

Replacement water filter cartridges (part #4204490) can be ordered by calling 800-768-0052 or online at [subzero.com](http://subzero.com).

## WATER FILTER CARTRIDGE REPLACEMENT

- 1) Lift the grille assembly to access the water filter. To lift the grille, pull out on the bottom edge of the grille and tilt the grille frame forward. Refer to the grille access illustration below.
- 2) Slowly rotate the old filter cartridge 1/4 turn counterclockwise to disengage. Gently twist until the cartridge is free from the base. DO NOT pull. There will be water in the filter cartridge, so it is normal for a small amount of water to spill out. Refer to the water filter illustration below.
- 3) Remove the new filter cartridge from its packaging and carefully remove the cap.
- 4) Line up the cartridge so that the locking tabs can be inserted into the filter head.
- 5) Rotate the filter cartridge into the base about 1/4 turn clockwise until it stops. DO NOT overtighten.
- 6) After the new filter cartridge is installed, the first full bucket of ice produced should be discarded. This will help clean the water system and clear air from the line. Allow 24 hours before discarding the first bucket of ice.

## WATER FILTER BYPASS MODE

If you choose not to use the water filtration system, the system can be placed in water filter bypass mode. In this mode, the water supplied to the ice maker will not be filtered and the electronically controlled water filter monitor will be deactivated.

The water filtration system automatically goes into bypass mode when the filter cartridge is removed. Once a filter cartridge is reinstalled, the water filtration system will be activated and the water filter monitor function will resume.

**IMPORTANT NOTE:** If you are using a reverse osmosis system, the water filter cartridge must be removed to put the water filtration system into bypass mode.

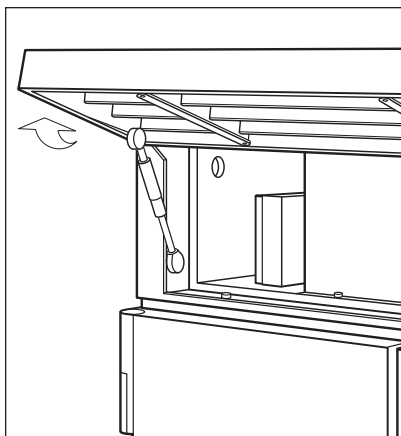

Grille access

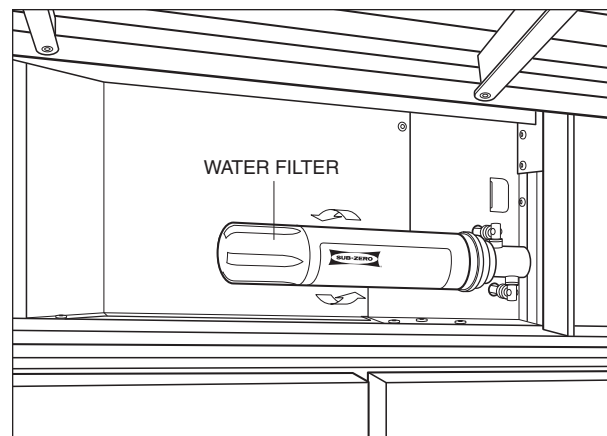

Water filter



### **ICE MAKER** OPERATION

The ice maker in the PRO 48 is fully automatic and has been tested at the Sub-Zero factory. To turn the ice maker on or off, depress the **ICE MAKER** key pad on the control panel. When the ice maker is on, it will be operating any time the drawer is closed.

**IMPORTANT NOTE:** A reverse osmosis system can be used with the PRO 48, provided there is constant water pressure of 20 psi (1.4 bar) to 120 psi (8.3 bar) supplied to the unit at all times. In this application, the integrated water filtration system must be set to bypass mode. This is achieved by removing the water filter cartridge. Refer to page 11 for detailed instructions.

### **ICE** PRODUCTION

The ice maker is designed to produce enough ice for normal family use. The timing of ice making cycles will vary depending on load conditions, door and drawer openings and room temperature. On average, you can expect a cycle of ice (eight cubes per cycle) every two hours.

For extra ice capacity, remove the ice bucket with the ice maker system on and allow the drawer to fill with ice.

**IMPORTANT NOTE:** Removing the ice bucket will not increase the rate of ice production.

If ice is not used on a regular basis it tends to fuse together. To avoid this, empty the ice bucket periodically allowing it to replenish with a fresh supply.

### **DOOR** AND **DRAWER** OPERATION

The PRO 48 refrigerator and freezer door hinges have an auto-close system that allows doors to finish closing automatically. As you close the door, the built-in cam takes over to close the door the final 15°. A built-in door stop allows both doors to stay open at approximately 120°.

For corner applications, an optional door stop kit is available that limits the door opening to 90° (part #4152280).

The PRO 48 refrigerator and freezer drawers have an auto-close system that allows drawers to finish closing automatically. The drawers have an automatic stop built in at full extension.



## INTERIOR CLEANING

To clean interior surfaces and removable parts, wash with a mild solution of soap and luke-warm water with a little baking soda. Do not use vinegar. Rinse and dry thoroughly. Avoid getting water on lights and control panel.

### ⚠ CAUTION

**Do not submerge or pour hot water over cold glass shelves.**

## EXTERIOR CLEANING

To clean the exterior stainless steel surfaces of the PRO 48, use a soft, nonabrasive stainless steel cleaner like Signature Polish and apply with a soft, 100% lint-free cloth.

To bring out the natural luster of the stainless steel, lightly wipe the surface with a water-dampened microfiber cloth followed by a dry polishing chamois. All work should follow the grain direction of the finish. Better results are obtained by keeping the cloth in continuous contact with the stainless steel.

Signature Polish is available from Signature Limited Laboratory, P. O. Box 13436, Dayton, Ohio 45413-0436, or 877-376-5474 (toll free).

### ⚠ CAUTION

**Under no circumstances should you use a metallic or highly abrasive cleaner or cloth, as this will scratch the classic stainless steel finish.**

## CONDENSER CLEANING

The condenser of the PRO 48 is located behind the grille at the top of the unit. The grille must be lifted to access the condenser area for cleaning. To lift the grille, pull out on the bottom edge of the grille and tilt the grille frame forward.

Use a soft bristle brush and vacuum to remove dust and lint from the condenser. Clean the condenser area every three to six months.

### ⚠ CAUTION

**Failure to clean the condenser could result in temperature loss or mechanical failure or damage.**

### ⚠ CAUTION

**Before cleaning the unit, shut the electricity off at the control panel. When you clean the condenser, wear gloves to avoid injury from the sharp condenser fins.**



### LIGHTING INFORMATION

The PRO 48 features top LED lights that bathe the upper refrigerator and freezer compartments in a soft glow. The refrigerator compartment also has channeled sidewall LED lighting.

For Model 648PROG with glass door, the LED lighting can be left on with the door closed and can serve as a door-area night light. This feature can be activated or deactivated by depressing the **LIGHT** key pad.

**IMPORTANT NOTE:** This advanced lighting system needs to be replaced by a Sub-Zero Factory Authorized Service Center technician.

The lighting in the refrigerator and freezer drawers use 40-watt appliance bulbs (part #3030180). The bulbs are easily accessible with the drawer open and are located on the ceiling of the drawer compartment.

To replace drawer compartment light bulbs, unscrew the bulb counterclockwise to remove and clockwise to install.

#### **⚠ WARNING**

**Be sure to shut off power to the unit at the circuit breaker before replacing light bulbs. Wear protective gloves when handling bulbs.**

### VACATION TIME

For extended vacations, shut off power to the unit by depressing the **POWER** key pad. Empty all contents and block the doors and drawers open slightly. A 1-inch (25 mm) space will allow fresh air in to keep the interior dry and fresh smelling.

For short vacations, remove all perishable items. Shut off the ice maker by pressing the **ICE MAKER** key pad and empty the ice bucket. It is not necessary to change the control settings.

If the unit is put into service temporarily and later shut off, block the doors and drawers open to allow fresh air to circulate inside the compartments. Be sure to shut off power to the unit by pressing the **POWER** key pad.

**IMPORTANT NOTE:** Refer to the water filtration system information for extended vacations on pages 10–11.

**IMPORTANT NOTE:** If the Sabbath Mode is required for turning off lights and the ice maker, refer to information on page 7.

KEEPING **FOOD FRESH**

Your Sub-Zero unit features our unique dual compressor refrigeration system to keep food fresher longer. However, the quality and safety of your food also depends on how you handle it.

The information in this section gives you the most up-to-date handling and storage recommendations to help you keep food at its best. If you have specific questions that are not addressed here, contact your University or County Extension Service or your local utility company.

Most food inevitably deteriorates over time. From the very beginning until it is consumed, food undergoes changes. Microorganisms get into food, multiply and cause spoiling.

Enzymes that occur naturally in food continue the ripening process even after the food is harvested. Improper temperatures cause food to deteriorate faster. Changes in humidity cause wilting and shriveling that can lead to spoiling.

Sub-Zero's exclusive dual refrigeration system is specifically designed to combat these changes and keep your food fresh longer. The individual refrigerator and freezer systems have been designed to maintain accurate, consistent temperatures and proper humidity levels for longer food life expectancy. Dual refrigeration eliminates transfer of fresh food odors to frozen food or ice and does not freeze the moisture out of the air in the fresh food compartment.

In addition, good handling practices can minimize the rate of changes in food.

- Follow the recommended storage times and temperatures in this guide. Your Sub-Zero unit helps to slow the ripening process by tailoring temperatures to each compartment as needed.
- Use specially designed compartments for dairy foods, deli foods and fresh produce. These compartments maintain temperature and humidity levels that keep specific food groups fresh.
- Rotate food in refrigeration units, using a first-in, first-out system.
- When food does spoil, it's usually obvious. It becomes moldy, has an off-odor, looks rotten or discolored. But there are times when spoiling may not be so apparent. If you think a food has been stored too long, discard it. Don't taste it to check if it's okay.
- While the bacteria that cause food spoilage will not cause food borne illness or food poisoning, taste tests are not a good idea.



KEEPING **FOOD SAFE TO EAT**

Most food borne illness is caused by bacteria such as staphylococcus, salmonella, E-coli and clostridium botulinum, the bacteria that causes botulism. These bacteria grow rapidly at temperatures between 40°F (4°C) and 140°F (60°C), a range that's called the **Danger Zone**. Never leave food in the danger zone for more than two hours. When the bacteria have multiplied to the millions in warm temperatures, they cause illness. Some bacteria cause flu-like symptoms, while others cause serious illness or even death. Young children, the elderly and people who are already ill are more likely to become sick from food poisoning.

To reduce your risk of food borne illness, use the following techniques to keep your food safe to eat:

**WHEN YOU'RE SHOPPING**

- Place packages of raw meat, seafood or poultry in plastic bags to keep them from dripping on other foods.
- Shop for meat, seafood and poultry last. Don't leave these foods in a hot car when you've finished shopping. Take along a cooler in hot weather or when you have to travel long distances.
- Check **use by** and **sell by** dates on foods to make sure they're fresh. Use extra care when buying deli food. Buy only the amount you will use in 1–2 days. Discard hot or cold deli food that has been at room temperature for more than two hours.

**WHEN YOU STORE FOOD**

- Monitor the temperature of refrigerator and freezer compartments in the exterior temperature displays of your PRO 48 unit. Keep the refrigerator temperature at 40°F (4°C) or below and freezer temperature at 0°F (-18°C).
- Follow the recommended refrigerator and freezer storage times and temperatures in this guide.
- Store raw meat, poultry and seafood separate from other foods. Keep juices from these packages from dripping on other food.
- Never taste food that looks or smells strange to test its freshness. Discard it.
- For refrigerator storage, leave raw meat, poultry and seafood in its original wrapper unless it is torn. Repeated handling can introduce bacteria to these foods.
- Wrap food stored in the refrigerator unit in foil or plastic wrap, or place it in plastic bags or airtight containers to keep it from drying out. Date all packages.
- For freezer storage, use freezer wrap, freezer-quality plastic bags or aluminum foil over the commercial wrap if foods will be stored in the freezer for more than a couple of months. This minimizes dehydration and quality loss. Single layers of aluminum foil may tear and cause freezer burn.

KEEPING **FOOD SAFE TO EAT****WHEN YOU PREPARE FOOD**

- Clean everything that comes in contact with food.
- Wash your hands for 20 seconds before and after handling food.
- Sanitize counters, equipment and utensils after handling raw meat, seafood or poultry. Rinse with a dilute chlorine bleach solution, one teaspoon to a quart of water.
- Use clean kitchen towels, sponges and cloths. Replace sponges every few weeks.
- Use disposable plastic gloves if you have an infected cut or burn on your hands.
- Thaw food in the refrigerator or microwave oven, not on the counter. When you thaw food in a microwave oven, cook it immediately.
- Marinate food only in the refrigerator.
- Rinse poultry and seafood in cold water before cooking.
- Avoid cross-contamination in preparing food. Keep raw meat, poultry and seafood and their juices away from other food. For example, don't use the same surface and utensils for preparing raw meat, poultry and seafood that you use for preparing salad ingredients.
- Thoroughly clean your plastic and wooden cutting boards. Wash with hot water and soap and rinse with a diluted chlorine bleach solution of one teaspoon to a quart of water.

**WHEN YOU COOK FOOD**

- Cook meat to an internal temperature of 165°F (74°C) or above, poultry to 180°F (82°C) or above. For cuts more than 2" (51 mm) thick, use a meat thermometer to check the temperature. For thinner cuts, clear juices (not pink) are a sign of doneness.
- If you are cooking frozen meat or poultry that has not been defrosted, increase the cooking time to 1½ times the time required for thawed items.
- Roast meats or poultry in oven temperatures of 325°F (163°C) or above.
- Cook eggs until the yolk and white are firm, not runny.
- Don't use recipes in which eggs remain raw or partially cooked.
- If your microwave has a temperature probe, use it. Check temperatures of meat and poultry in at least three spots. Rotate foods during microwaving.
- Don't taste raw or partially cooked meat, poultry, eggs or fish.

**WHEN YOU HAVE LEFTOVERS**

- Refrigerate or freeze cooked leftovers in small, covered containers within 2 hours after cooking. Make sure there is adequate air space around the containers so that food can cool down quickly.
- Remove the stuffing from meat or poultry and store it separately.
- Date packages of leftovers and use within a safe period of time.
- Cover and reheat leftovers thoroughly before serving.
- Bring sauces, soups and gravy to a boil. Heat other foods to 165°F (74°C).
- If you think food may be spoiled, discard it. When in doubt, throw it out.

**FRESH FOOD STORAGE**

Shelf life of fresh foods varies depending on how fresh it is when you buy it. To keep your food fresher longer, follow the recommended storage tips.

**Vegetables:** Wash vegetables in cool water and drain. Store in airtight containers or plastic wrap. Vegetables stay fresh longer in high humidity storage.

**Fruits:** Wash and dry fresh fruits. Store more aromatic fruits in plastic bags. Most fruits stay fresh longer in low humidity storage.

**Prepackaged Meats:** Store in original packaging. After opening, rewrap tightly in plastic wrap or aluminum foil.

**Fresh Meats, Fish and Poultry:** Remove store wrappings, then rewrap in plastic wrap, foil or waxed paper and refrigerate immediately.

**Eggs:** Store eggs unwashed in their carton or a portable egg tray. Use within 2 weeks.

**Milk, Cream and Cottage Cheese:** Keep carton closed. Store on refrigerator shelf and use within 5 days.

**Cheese:** Store in original packaging until ready to use. After opening, rewrap tightly in plastic wrap or aluminum foil.

**Leftovers:** Let cool and cover tightly with plastic wrap or foil. Airtight plastic containers work well to prevent drying out and odor transfer.

**FROZEN FOOD STORAGE**

**Freezer Storage:** Wrap foods in material designed for frozen food storage. The wrap must seal out air and moisture. **Do not refreeze thawed meats.**

**Ice Cream:** The firmness of the ice cream will depend on its cream content. Higher quality ice creams usually have a higher cream content, requiring colder freezer temperatures to maintain their firmness. Soft ice cream is not always an indication of a temperature problem.

Make sure your refrigerator and freezer doors close freely and completely. Overloading will affect temperatures inside the unit. Do not fill your freezer with large quantities of unfrozen foods expecting them to fast freeze. Give the freezer ample time to circulate cold air around unfrozen items before adding additional items.

**SUGGESTED FOOD STORAGE**

The food storage charts on the following pages give you specific information to help you keep food safe and keep it at its best quality. The recommended storage temperatures will help you determine optimal storage conditions for your food. As a general rule, food that is handled properly and kept at temperatures below 40°F (4°C) will be safe to eat.

Storing food at temperatures below 40°F (4°C) keeps it out of the **Danger Zone**. The storage times for refrigeration will help keep food from spoiling or becoming dangerous to eat. The time limits for frozen foods are to maintain flavor and texture. Food kept frozen longer than the recommended time will still be safe to eat, but its quality may diminish.



**FISH, MEATS AND POULTRY**

	Recommended Temperature	Storage Life (refrigerator)	Storage Life (freezer)*	Comments
<b>FRESH FISH &amp; SEAFOOD</b>				
cod, flounder, haddock	32°F (0°C)	2 days	6 months	Freeze in original wrap up to 2 weeks. Use freezer wrap, freezer-quality plastic bags or aluminum foil over the commercial wrap if foods will be frozen for more than a couple of months.
sole bluefish, perch	32°F (0°C)	2 days	2–3 months	
mackerel, salmon	32°F (0°C)	4 days	5–9 months	
shrimp, oysters	32°F (0°C)	1 day	6 months	
<b>FRESH MEAT</b>				
beef steaks, roasts	32–35°F (0–2°C)	3–5 days	6–12 months	Freeze in original wrap up to 2 weeks. Use freezer wrap, freezer-quality plastic bags or aluminum foil over the commercial wrap if foods will be frozen for more than a couple of months.
lamb chops, roasts	32–35°F (0–2°C)	3–5 days	6–9 months	
pork and veal chops, roasts	32–35°F (0–2°C)	3–5 days	4–6 months	
variety meats (tongue, liver, etc.)	32–35°F (0–2°C)	1–2 days	3–4 months	
<b>HAMBURGER, GROUND &amp; STEW MEATS</b>				
hamburger, stew meats, ground turkey, veal, pork, lamb and mixtures	32–35°F (0–2°C)	1–2 days	3–4 months	Freeze in original wrap up to 2 weeks. Use freezer wrap, freezer-quality plastic bags or aluminum foil over the commercial wrap if foods will be frozen for more than a couple of months.
<b>HOTDOGS &amp; LUNCH MEATS</b>				
hotdogs (opened package)	32–35°F (0–2°C)	1 week	1–2 months	Freeze in freezer wrap. Check “sell by” dates. Do not use more than 1 week after this date.
hotdogs (unopened package)	32–35°F (0–2°C)	2 weeks	1–2 months	
lunch meats (opened package)	32–35°F (0–2°C)	3–5 days	1–2 months	
lunch meats (unopened package)	32–35°F (0–2°C)	2 weeks	1–2 months	
<b>BACON &amp; SAUSAGE</b>				
bacon	32–35°F (0–2°C)	7 days	1 month	Keep wrapped, and store at recommended refrigerator temperatures.
raw sausage (pork, beef, turkey)	32–35°F (0–2°C)	1–2 days	1–2 months	
smoked breakfast links or patties	32–35°F (0–2°C)	7 days	1–2 months	
hard sausage (pepperoni, jerky sticks)	32–35°F (0–2°C)	2–3 weeks	1–2 months	
<b>HAM &amp; CORNED BEEF</b>				
corned beef	32–35°F (0–2°C)	5–7 days	1 month	For freezer storage, drain juices.
ham, whole	32–35°F (0–2°C)	7 days	1–2 months	
ham, half	32–35°F (0–2°C)	3–5 days	1–2 months	
ham, slices	32–35°F (0–2°C)	3–4 days	1–2 months	
<b>FRESH POULTRY</b>				
chicken or turkey, whole	32–35°F (0–2°C)	1–2 days	12 months	Freeze in original wrap up to 2 weeks. Use freezer wrap, freezer-quality plastic bags or aluminum foil over the commercial wrap if foods will be frozen for more than a couple of months.
chicken or turkey, pieces	32–35°F (0–2°C)	1–2 days	9 months	
duck or goose	32–35°F (0–2°C)	1–2 days	6 months	

\*Recommended freezer storage temperature is 0°F (-18°C).

FRESH VEGETABLES

	Recommended Temperature	Storage Life (refrigerator)	Comments	
<b>FRESH VEGETABLES</b>				
anise	34–36°F (1–2°C)	2–3 weeks	Wash vegetables in cool water and drain. Store in airtight container or plastic wrap.	
artichokes	34°F (1°C)	1–2 weeks		
asparagus	34–36°F (1–2°C)	2–3 weeks		
beans, green/snap/lima*	40–45°F (4–7°C)	10–14 days		
bean sprouts	34°F (1°C)	7–9 days		
beets	34°F (1°C)	3–5 months		
belgian endive	36–38°F (2–3°C)	2–4 weeks		
bok choy	34°F (1°C)	3 weeks		
broccoli	34°F (1°C)	1–2 weeks	Most vegetables should be stored in higher humidity. Discard any fresh vegetables that are moldy or have other signs of spoilage and wipe out the refrigerator compartment. For fresh-cut produce, follow storage directions on package.	
brussels sprouts	34°F (1°C)	3–5 weeks		
cabbage	34°F (1°C)	3–6 months		
carrots	34°F (1°C)	1–5 months		
cauliflower	34°F (1°C)	3–4 weeks		
celeriac	34°F (1°C)	6–8 months		
celery	34°F (1°C)	2–4 weeks		
chinese broccoli	34°F (1°C)	10–14 days		
chinese cabbage	34°F (1°C)	2–3 months		Refer to the list of ethylene sensitive and ethylene producing vegetables and fruits.
corn, sweet	34°F (1°C)	4–6 days		
cucumbers*	45–50°F (7–10°C)	1–2 weeks		
daikon	34°F (1°C)	4 months		
eggplant*	45–50°F (7–10°C)	1–2 weeks		
endive/escarole	34°F (1°C)	2–3 weeks		
garlic	34°F (1°C)	3–6 months		
ginger root*	55°F (13°C)	6 months		
horseradish	34°F (1°C)	10–12 months		
jerusalem artichokes	34°F (1°C)	1–2 weeks		
jicama*	55–65°F (13–18°C)	4–5 months		
kale	34°F (1°C)	1–2 months		
kohlrabi	34°F (1°C)	10–14 days		
leeks	34°F (1°C)	2–3 months		
lettuce	34°F (1°C)	2–3 weeks		
mushrooms	34°F (1°C)	2–3 weeks		
okra*	45–50°F (7–10°C)	1–2 weeks		
onions, bulb	34°F (1°C)	1–6 months		
onions, green	34°F (1°C)	7–10 days		
parsley	34°F (1°C)	1–2 months		
parsnips	34°F (1°C)	4–5 months		
peas, pods and shelled	34°F (1°C)	7–10 days		
peppers, bell*	45–50°F (7–10°C)	12–18 days		
peppers, chile	45–50°F (7–10°C)	2–3 weeks		

\*Sensitive to chill injury, a cause of spoilage. Damage may not be apparent until the vegetable is returned to a warmer temperature.

NOTE: See food preservation guide for complete instructions on freezing vegetables. Recommended freezer storage temperature is 0°F (-18°C).



FRESH VEGETABLES

	Recommended Temperature	Storage Life (refrigerator)	Comments
<b>FRESH VEGETABLES</b>			
potatoes	45–50°F (4–10°C)	2–4 months	Wash vegetables in cool water and drain. Store in airtight container or plastic wrap.
pumpkins*	38–55°F (3–13°C)	3–4 months	
radicchio	34°F (1°C)	2–3 weeks	
radishes	34°F (1°C)	3–4 weeks	
romaine	34°F (1°C)	2–3 weeks	
rutabagas	34°F (1°C)	4–6 months	
salsify	34°F (1°C)	2–4 months	
shallots	34°F (1°C)	6 months	
snow peas	34°F (1°C)	1–2 weeks	Most vegetables should be stored in higher humidity. Discard any fresh vegetables that are moldy or have other signs of spoilage and wipe out the refrigerator compartment. For fresh-cut produce, follow storage directions on package.
spinach	34°F (1°C)	1–2 weeks	
squash, summer*	40–50°F (4–10°C)	1–2 weeks	
squash, winter	50–55°F (10–13°C)	3–5 months	
sweet potatoes*	55–60°F (13–16°C)	4–7 months	
tamarillos	37–40°F (3–4°C)	2 months	
tomatoes (ripe)	34–40°F (1–4°C)	3–4 weeks	
turnips	34°F (1°C)	4–5 months	
water chestnuts	34–36°F (1–2°C)	1–2 months	Refer to the list of ethylene sensitive and ethylene producing vegetables and fruits.
watercress	34°F (1°C)	2–3 weeks	

\*Sensitive to chill injury, a cause of spoilage. Damage may not be apparent until the vegetable is returned to a warmer temperature.

NOTE: See food preservation guide for complete instructions on freezing vegetables. Recommended freezer storage temperature is 0°F (-18°C).

FRESH FRUITS

	Recommended Temperature	Storage Life (refrigerator)	Comments	
<b>FRESH FRUITS</b>				
apples	34–40°F (1–4°C)	3–6 months	Wash and dry most fruits, and store in crisper compartment. (Do not wash berries and cherries until you are ready to use them, however.)	
apricots	34°F (1°C)	1–2 weeks		
asian pears	34°F (1°C)	5–6 months		
avocados*	40°F (4°C)	2–4 weeks		
blackberries	34°F (1°C)	2–3 days		
blood oranges	40–44°F (4–7°C)	3–8 weeks		
blueberries	34°F (1°C)	10–18 days		
cantaloupe*	36–40°F (2–4°C)	10–14 days		
<hr/>				
cassavas	34°F (1°C)	1–2 months	Most fruits should be stored in lower humidity. Fully ripe fruits should be stored in the refrigerator at recommended temperatures to slow down the ripening process. Unripe fruits should be left to ripen at room temperature, in a container that allows for air circulation.	
cherries, sweet	34°F (1°C)	2–4 weeks		
clementines	40°F (4°C)	2–4 weeks		
cranberries*	36–40°F (2–4°C)	2–4 months		
figs, fresh	34°F (1°C)	7–10 days		
grapefruit*	50–60°F (10–16°C)	4–6 weeks		
grapes	34°F (1°C)	8–12 days		
guavas*	40–50°F (4–10°C)	2–3 weeks		
<hr/>				
honeydew	45–50°F (7–10°C)	3–4 weeks		To hasten the ripening process, you can place unripe fruit in a paper bag that has holes poked in it. Close the bag and set it on a counter. The fruit will produce ethylene, a gas that initiates the ripening process. Check the bag each day. Discard any fresh fruits that are moldy or have other signs of spoilage and wipe out the refrigerator compartment.
kiwifruit	34°F (1°C)	4–6 weeks		
kumquats	40°F (4°C)	2–4 weeks		
lemons*	50–55°F (10–13°C)	1–5 months		
limes*	48–50°F (9–10°C)	3–5 weeks		
lychees	35°F (2°C)	3–5 weeks		
mangoes*	50°F (10°C)	2–3 weeks		
nectarines	34°F (1°C)	2–4 weeks		
<hr/>				
oranges*	34–48°F (1–9°C)	3–8 weeks	Refer to the list of ethylene sensitive and ethylene producing vegetables and fruits.	
papayas*	45–55°F (7–13°C)	1–3 weeks		
peaches	34°F (1°C)	2–4 weeks		
pears	34°F (1°C)	2–3 weeks		
persimmons	34°F (1°C)	3–4 months		
pineapple*	45°F (7°C)	2–5 weeks		
plums and prunes	34°F (1°C)	2–4 weeks		
pomegranates*	40°F (4°C)	2–3 months		
<hr/>				
quinces	34°F (1°C)	2–3 months		
raspberries	34°F (1°C)	2–3 days		
rhubarb	34°F (1°C)	2–3 weeks		
strawberries	34°F (1°C)	5–10 days		
tangerines	40°F (4°C)	2–4 weeks		
watermelon*	45–55°F (7–13°C)	2–3 weeks		

\*Sensitive to chill injury, a cause of spoilage. Damage may not be apparent until the fruit is returned to a warmer temperature.

NOTE: See food preservation guide for complete instructions on freezing fruits. Recommended freezer storage temperature is 0°F (-18°C).

**DELI FOODS, DAIRY PRODUCTS AND OTHER FOODS**

	<b>Recommended Temperature</b>	<b>Storage Life (refrigerator)</b>	<b>Storage Life (freezer)*</b>	<b>Comments</b>
<b>DELI FOODS</b>				
thinly sliced lunch meats	32–35°F (0–2°C)	1–2 days	NR	Check “use by” or “sell by” dates. These foods do not freeze well. If you need to freeze, do so immediately, not after they have been held in the refrigerator.
egg, chicken, tuna and ham salads	32–35°F (0–2°C)	3–5 days	NR	
macaroni salads	32–35°F (0–2°C)	3–5 days	NR	
pre-stuffed chops, chicken breasts	32–35°F (0–2°C)	1 day	NR	
store-prepared convenience meals	32–35°F (0–2°C)	1–2 days	NR	
<b>DAIRY FOODS</b>				
butter	32–35°F (0–2°C)	3 months	1 year	Check “sell by” dates.
cottage or ricotta cheese	32–35°F (0–2°C)	1–2 weeks	4 weeks	
cream cheese	32–35°F (0–2°C)	2 weeks		Store cheese in original packaging until ready to use. After opening, rewrap tightly in plastic wrap or aluminum foil.
natural cheese (cheddar, brick, etc.)	32–35°F (0–2°C)	3–6 months	6–8 months	
process cheese	32–35°F (0–2°C)	3–4 weeks	6–8 months	
grated Parmesan or Romano	32–35°F (0–2°C)	1 year		Thaw frozen cheese in the refrigerator to reduce crumbling.
yogurt	32–35°F (0–2°C)	1 month		
whole, lowfat or skim milk	32–35°F (0–2°C)	1–2 weeks		
<b>EGGS</b>				
fresh, in shell	32°F (0°C)	3 weeks	NR	Keep fresh eggs refrigerated.
hard cooked	32–35°F (0–2°C)	1 week	NR	
liquid pasteurized or egg substitutes				Do not eat hard cooked eggs that have been at room temperature for more than 2 hours.
opened	32–35°F (0–2°C)	3 days	NR	
unopened	32–35°F (0–2°C)	10 days	1 year	
<b>COOKED MEAT &amp; POULTRY LEFTOVERS</b>				
cooked meat and meat dishes	32–35°F (0–2°C)	3–4 days	2–3 months	Refrigerate or freeze leftovers in covered shallow containers within 2 hours after cooking. Reheat leftovers to 165°F (74°C).
gravy and meat broth	32–35°F (0–2°C)	1–2 days	2–3 months	
fried or plain chicken, pieces	32–35°F (0–2°C)	3–4 days	4 months	
cooked poultry dishes	32–35°F (0–2°C)	3–4 days	4–6 months	
pieces covered with broth, gravy	32–35°F (0–2°C)	1–2 days	6 months	
chicken nuggets, patties	32–35°F (0–2°C)	1–2 days	1–3 months	
<b>SOUPS &amp; STEWS</b>				
vegetable	32–35°F (0–2°C)	3–4 days	2–3 months	Reheat to at least 165°F (74°C) before serving.
meat added	32–35°F (0–2°C)	3–4 days	2–3 months	

\*Recommended freezer storage temperature is 0°F (-18°C). (NR) stands for not recommended for freezing.

**ETHYLENE**

Some fruits and vegetables will produce ethylene, a gas that initiates the ripening process. Ethylene can cause premature ripening in some foods, while in others, it can actually cause damage.

To reduce unnecessary spoilage of your produce, do not store ethylene producing fruits and vegetables with those that are sensitive to it. Refer to the following lists.

---

**ETHYLENE PRODUCING FOODS**

- |                  |               |
|------------------|---------------|
| apples           | mangosteen    |
| apricots         | nectarines    |
| avocados         | papayas       |
| ripening bananas | passion fruit |
| cantaloupe       | peaches       |
| cherimoyas       | pears         |
| figs             | persimmons    |
| guavas           | plantains     |
| honeydew         | plums         |
| kiwifruit        | prunes        |
| mamey sapote     | quince        |
| mangoes          | tomatoes      |

---

**ETHYLENE SENSITIVE FOODS**

- |                  |                |
|------------------|----------------|
| unripe bananas   | leafy greens   |
| green beans      | lettuce        |
| belgian endive   | okra           |
| broccoli         | parsley        |
| brussels sprouts | peas           |
| cabbage          | peppers        |
| carrots          | spinach        |
| cauliflower      | squash         |
| chard            | sweet potatoes |
| cucumbers        | watercress     |
| eggplant         | watermelon     |
| unripe kiwifruit |                |

---

*NOTE: Do not store ethylene producing foods with ethylene sensitive foods.*



## Performance Data Sheet

### Sub-Zero Water Filtration System Model 4290510 Replacement Cartridge #4204490



Tested and certified by NSF International against NSF/ANSI Standard 42 for the reduction of Chlorine Taste and Odor, Particulate Class I; and against NSF/ANSI Standard 53 for the reduction of Lead, Mercury, Atrazine, Benzene, Carbofuran, 1,4-dichlorobenzene, Lindane, Toxaphene, Turbidity, Cysts and Asbestos.

This system has been tested according to NSF/ANSI 42/53 for reduction of the substances listed below. The concentration of the indicated substances in water entering the system was reduced to a concentration less than or equal to the permissible limit for water leaving the system, as specified in NSF/ANSI 42/53.

Standard No. 42: Aesthetic Effects								
Parameter	USEPA MCL	Influent Challenge Concentration (mg/L)	Average Influent Concentration (mg/L)	Product Water Concentration		% Reduction		Maximum Permissible Product Water Concentration
				Average	Max. Effluent	Average	Minimum	
Chlorine	—	2.0 mg/L ± 10%	1.88 mg/L	0.05 mg/L	0.06 mg/L	97.34%	96.80%	≥ 50%
T & O	—	—	—	—	—	—	—	—
Particulate	—	At least 10,000 particles/ml	5,700,000/ml	30,583/ml	69,000/ml	99.46%	98.78%	≥ 85%

Standard No. 53: Health Effects								
Parameter	USEPA MCL	Influent Challenge Concentration	Average Influent Concentration (mg/L)	Effluent		% Reduction		Maximum Permissible Product Water Concentration
				Average	Maximum	Average	Minimum	
Lead at pH 6.5	0.015 mg/L	0.15 mg/L ± 10%	0.153 mg/L	<0.001 mg/L	<0.001 mg/L	99.34%	99.34%	0.010 mg/L
Lead at pH 8.5	0.015 mg/L	0.15 mg/L ± 10%	0.150 mg/L	<0.001 mg/L	<0.001 mg/L	99.33%	99.33%	0.010 mg/L
Mercury at pH 6.5	0.002 mg/L	0.006 mg/L ± 10%	0.006 mg/L	0.0003 mg/L	0.0005 mg/L	95.00%	91.66%	0.002 mg/L
Mercury at pH 8.5	0.002 mg/L	0.006 mg/L ± 10%	0.006 mg/L	0.0008 mg/L	0.0015 mg/L	86.66%	75.00%	0.002 mg/L
Atrazine	0.003 mg/L	0.009 mg/L ± 10%	0.009 mg/L	<0.002 mg/L	<0.002 mg/L	77.77%	77.77%	0.003 mg/L
Benzene	0.005 mg/L	0.015 mg/L ± 10%	0.014 mg/L	0.0006 mg/L	0.0011 mg/L	95.71%	92.14%	0.005 mg/L
Carbofuran	0.04 mg/L	0.08 mg/L ± 10%	0.081 mg/L	<0.001 mg/L	<0.001 mg/L	98.76%	98.76%	0.04 mg/L
1,4-dichlorobenzene	0.075 mg/L	0.225 mg/L ± 10%	0.208 mg/L	<0.0005 mg/L	<0.0005 mg/L	99.75%	99.75%	0.075 mg/L
Lindane	0.0002 mg/L	0.002 mg/L ± 10%	0.002 mg/L	0.00003 mg/L	0.00007 mg/L	98.50%	96.50%	0.0002 mg/L
Toxaphene	0.003 mg/L	0.015 mg/L ± 10%	0.015 mg/L	<0.001 mg/L	<0.001 mg/L	93.33%	93.33%	0.003 mg/L
Turbidity	1 NTU*	11 ± 1 NTU	10.7 NTU	0.31 NTU	0.49 NTU	97.10%	95.42%	0.5 NTU
Cysts**	99.95% Reduction	Minimum 50,000/L	166,500/L	<1/L	<1/L	>99.99%	>99.99%	>99.95%
Asbestos	99% Reduction	10 <sup>7</sup> to 10 <sup>8</sup> fibers/L†	155 MF/L	<1 MF/L	<1 MF/L	>99.99%	>99.99%	>99%

\*NTU - Nephelometric Turbidity Units; \*\* Based on the use of *Cryptosporidium Parvum* oocysts; † Fibers greater than 10 micrometers in length

Operating Specifications

- Capacity: certified for up to 750 gallons (2,838 L); up to twelve months
- Pressure Requirement: 35 – 120 psi (2.8 – 8.2 bar)
- Temperature: 33 – 100°F (0.6 – 38°C)
- Flow Rate: 0.78 gpm (2.9 Lpm)

Special Notices

For a replacement element please contact @ 1-800-768-0052 or order online at [www.subzero.com](http://www.subzero.com)  
 Change cartridge at least every twelve months.  
 Installation and operation instructions, parts and service availability and standard warranty are included with the product when shipped.  
 Replace water filter cartridge when filter indicator is lit or when water flow becomes too low. Use replacement water filter cartridge part number 4204490. Replacement filter pricing information can be found at [www.subzero.com](http://www.subzero.com).  
 Do not use with water that is microbiologically unsafe or of unknown water quality without adequate disinfection before or after the system.  
 Systems certified for cyst reduction may be used on disinfected waters that may contain filterable cysts.  
 This system must be installed, operated, maintained and filters replaced as required in order for the product to perform as advertised.  
 Note that while the testing was performed under standard laboratory conditions, actual performance may vary. The contaminants or other substances removed or reduced by this water treatment system are not necessarily in your water.



State of California  
Department of Health Services  
Water Treatment Device  
Certificate Number

05 - 1708

Date Issued: April 18, 2005

---

---

**Trademark/Model Designation**

Sub-Zero 4290510

**Replacement Elements**

4204490

---

---

**Manufacturer:** Cuno, Incorporated

---

---

**The water treatment device(s) listed on this certificate have met the testing requirements pursuant to Section 116830 of the Health and Safety Code for the following health related contaminants:**

**Microbiological Contaminants and Turbidity**

Cysts  
Turbidity

**Inorganic/Radiological Contaminants**

Asbestos  
Lead  
Mercury

**Organic Contaminants**

Atrazine  
Benzene  
Carbofuran  
Lindane  
p-dichlorobenzene  
Toxaphene

---

---

**Rated Service Capacity:** 750 gals

**Rated Service Flow:** 0.78 gpm

---

---

**Conditions of Certification:**

Do not use where water is microbiologically unsafe or with water of unknown quality, except that systems certified for cyst reduction may be used on disinfected waters that may contain filterable cysts.

## TROUBLESHOOTING

If your refrigerator or freezer is not operating properly, use the following troubleshooting guide before calling your Factory Authorized Service Center. This guide will save you time and trouble and may avoid the expense of a service call.

**SERVICE is illuminated in the exterior temperature display**

- The microprocessor has sensed a problem with the operating system. There may be instructions in the exterior temperature display to solve the problem. If not, call the Sub-Zero Customer Service Department at 800-222-7820.

**SERVICE is flashing in the exterior temperature display**

- This happens when one or more of the zones runs too long, or a temperature sensor may be faulty. This could be from a dirty condenser. If this occurs, clean the condenser following the procedure outlined on page 13. Turn the unit off with the **POWER** key pad and then restart by depressing the key pad again. If SERVICE is still flashing, call the Sub-Zero Customer Service Department at 800-222-7820.

**Service and ice lights are both flashing**

- This occurs when the solenoid valve for the ice maker is activated too long. Check for excess water near the ice maker. If you see excess water, turn off the water at the shut-off valve and call for service. If there is no excess water, turn the unit off and back on to reset and see if this corrects the problem. If the problem continues, call the Sub-Zero Customer Service Department at 800-222-7820.

**Refrigerator/Freezer is not running**

- Is there electrical power to the unit?
- Is your home circuit breaker or fuse off?
- Is your refrigerator/freezer control set to "ON"?
- Is the condenser area clean?
- Has either door been left open for an extended period? Be sure that food is not obstructing proper door or drawer closing.
- If unit has been off for short time frame and unit is still not running, it may be in defrost mode.
- Wait 30 minutes and try to restart again.

**Refrigerator/Freezer is warmer than usual**

- Is your control set properly?
- Is your condenser area clean?
- Has the door been open for a long time?
- Have you recently added a large amount of food?

**Refrigerator/Freezer runs for long periods of time**

- Is the condenser area clean?
- On hot days and in warm room temperatures, the motor runs longer.
- Have the doors or drawers been open for a long time?
- Have you recently added a large amount of food?
- Has either a door or drawer been left open accidentally? Be sure that food is not obstructing door or drawer from closing.
- There may be normal operation noises related to refrigerant circulation, fan operation, ice maker operation, defrost cycle or compressor operation.

TROUBLESHOOTING

**Refrigerator/Freezer is frosted up**

- Has a door or drawer been left open for an extended period?
- Are doors and drawers closing and sealing properly? Contact your dealer if doors or drawers are not adjusted properly. NOTE: When opening drawers, you may notice a side-to-side motion in the drawer. This motion is normal, with the tolerance built into the drawer slides. When the drawer is closed, it will automatically adjust and close with correct alignment.

**You hear unusual noises**

- These noises may be normal operating sounds related to refrigerant circulation, fan operation, ice maker operation, defrost cycle or compressor operation.

**You hear occasional buzzing**

- Is the water supply connected to ice maker and turned on?

**Condensation forms inside the unit**

- This is normal during periods of higher humidity (summer) and with frequent door openings.
- Are doors and drawers closing and sealing properly?

**Condensation forms outside the unit**

- During periods of high humidity, some condensation may appear on outside surfaces. The condensation will disappear when the humidity drops. Be sure doors and drawers are closing and sealing properly. If condensation persists, contact your Factory Authorized Service Center.

**Outside of the freezer compartment heats up**

- Clean the condenser area.

**There is no ice**

- Is the ice maker turned on?
- Is the water supply connected?

**Food has created an odor inside the unit**

- Clean the unit thoroughly
- Cover all food tightly
- Discard outdated food

**Light bulb needs to be replaced**

- See Lighting Information, page 14.

**⚠ WARNING**

**Shut off power to the unit at the circuit breaker before replacing light bulbs. Wear protective gloves when handling bulbs.**

**You need product information**

- Call Sub-Zero Customer Service Department at 800-222-7820 or visit our website, [subzero.com](http://subzero.com), for planning, installation and product information.

**You need service**

- Check the model and serial number of your unit on the plate located on the left side of the top freezer drawer compartment. Call your Sub-Zero Factory Authorized Service Center; contact your dealer or the Sub-Zero Customer Service Department, P. O. Box 44130, Madison, WI 53744-4130; call 800-222-7820; or e-mail us at [customerservice@subzero.com](mailto:customerservice@subzero.com). You may also check the service center locator on our website, [subzero.com](http://subzero.com).

## FREQUENTLY ASKED QUESTIONS

## ICE PRODUCTION

**IMPORTANT NOTE:** Make sure that the ice maker system is on. The ice bucket icon will be visible in the exterior temperature display if the ice maker system is on. If it is not on, use the **ICE MAKER** key pad on the control panel to turn on power to the ice maker system.

**IMPORTANT NOTE:** Dispose of the first bucket of ice produced by your new unit to ensure that pipe residue or other particles associated with new water lines are not consumed.

**Q:** My ice maker isn't producing very much ice.

**A:** On average, you can expect a cycle of ice (eight cubes per cycle) every two hours.

**Q:** My ice is freezing together and clumping.

**A:** If ice is not used regularly it tends to fuse together. You may need to discard the ice and allow ice to be replenished.

**Q:** My ice tastes funny and is discolored.

**A:** The PRO 48 has a water filtration system built into the ice maker water line. The water filter cartridge should be replaced if the unit has been turned off for one month or more, or if the water filter cartridge has been in use for more than one year. Contact a plumber or water treatment contractor to discuss options for other source water condition problems.

## NOISE

**Q:** Why do I hear my unit running constantly?

**A:** It is normal to hear the operation of fans and motors from the product. Sounds will be accentuated based on the placement of the unit and overall room design.

## TEMPERATURE

**IMPORTANT NOTE:** Unless the unit is being serviced, make sure the power for your unit is on. If the unit is not on, OFF will be visible in the exterior temperature display. Use the **POWER** key pad on the control panel to turn on power to the unit.

**Q:** How do I adjust the temperatures in my unit?

**A:** To adjust temperatures, refer to Temperature Control, page 6.

**Q:** What are the suggested temperature settings?

**A:** The recommended settings are 38°F (3°C) for refrigerator compartments and 0°F (-18°C) for freezer compartments.

**Q:** Condensation is forming on the inside and outside of my unit.

**A:** In climates with higher humidity, condensation will form and is considered normal. Leaving the door open for a long period of time may also contribute to condensation forming on the inside your unit.

**Q:** My unit isn't cooling properly.

**A:** Clean the condenser area as outlined on page 13.

## DOOR OPERATION

**Q:** Why is my door hard to open?

**A:** Your unit was designed for an airtight seal. A vacuum seal can form after the door is closed. Wait several seconds for pressure to equalize before reopening the door.

**Q:** The door on my unit is opening too fast and hitting the wall or surrounding cabinets.

**A:** The unit may not be leveled properly or a door stop may be required. Contact your Sub-Zero dealer for details on the door stop kit.



SERVICE INFORMATION

This Use & Care Information book gives you the tools necessary to preserve food at optimum quality in your PRO 48 unit. Keep doors and drawers closed as much as possible whenever the unit is operating.

If you do need service, be sure to have the model and serial number when you call. You'll find these numbers on the model and serial number plate located on the left side of the top freezer drawer compartment. For warranty purposes, you will also need the date of installation and the name of your Sub-Zero dealer. Record this information below for future reference.

Model Number \_\_\_\_\_

Serial Number \_\_\_\_\_

Installation Date \_\_\_\_\_

Factory Authorized Service Center and Phone  
\_\_\_\_\_

Sub-Zero Dealer and Phone  
\_\_\_\_\_

BEFORE CALLING FOR SERVICE

Before calling your Sub-Zero Factory Authorized Service Center, refer to the Troubleshooting Guide on pages 27-29. Check the household fuse or circuit breaker to see if it has been blown or tripped and that the electrical connection to the appliance has not been disconnected. A power outage may also have caused a disruption in service.

CONTACT INFORMATION

Sub-Zero  
Customer Service:  
800-222-7820

Website:  
subzero.com

E-mail Address:  
customerservice@  
subzero.com

PRODUCT REGISTRATION

Register your new Sub-Zero today so that we may ensure your satisfaction. You may register by one of the following options:

- 1) Mail in the completed Sub-Zero Product Registration Card.
- 2) Register online at **subzero.com**.
- 3) Register by phone by calling the Sub-Zero Customer Service Department at **800-222-7820**.

The model and serial numbers of your unit are printed on the enclosed Sub-Zero Product Registration Card. Your registration information will allow us to send you exciting new product updates and recipes as they become available, along with information on special events.

The information and images in this guide are the copyright property of Sub-Zero Freezer Company, Inc. Neither this book nor any information or images contained herein may be copied or used in whole or in part without the express written permission of Sub-Zero Freezer Company, Inc.

©Sub-Zero Freezer Company, Inc. all rights reserved.

# **SUB-ZERO FREEZER COMPANY PRODUCTS LIMITED WARRANTY**

RESIDENTIAL USE ONLY

## **FULL FIVE YEAR SEALED SYSTEM WARRANTY LIMITED SIXTH THROUGH TWELFTH YEAR WARRANTY ON THE SEALED SYSTEM FULL TWO YEAR WARRANTY ON TOTAL PRODUCT\***

### **FULL FIVE YEAR SEALED SYSTEM WARRANTY**

For five years from the date of original installation, your Sub-Zero warranty covers all parts and labor to repair or replace any components that prove to be defective in materials or workmanship in the sealed system. The sealed system consists of the compressor, condenser, evaporator, drier and all connecting tubing.

### **FULL TWO YEAR WARRANTY\***

For two years from the date of original installation, your Sub-Zero warranty covers all parts and labor to repair or replace any part of the product, that proves to be defective in materials or workmanship.

### **LIMITED SIXTH THROUGH TWELFTH YEAR SEALED SYSTEM WARRANTY**

From the 6th through the 12th year from the date of original installation, your Sub-Zero warranty covers all parts that prove to be defective in materials or workmanship in the sealed system (parts only). The sealed system consists of the compressor, condenser, evaporator, drier and all connecting tubing.

### **TERMS APPLICABLE TO EACH WARRANTY**

All service provided by Sub-Zero under the above warranty must be performed by an authorized Sub-Zero service center, unless otherwise specified by Sub-Zero. Service will be provided in the home during the normal business hours. This warranty applies only to products installed for normal residential use. Details regarding a non-residential warranty are available upon request.

The warranty applies only to products installed in any one of the fifty states of the United States, the District of Columbia or the ten provinces of Canada. This warranty does not cover any parts or labor to correct any defect caused by negligence, accident or improper use, maintenance, installation, service or repair, including but not limited to improper removal and reinstallation (whether in the unit or at a remote location) of the condensing unit.

**THE REMEDIES DESCRIBED ABOVE FOR EACH WARRANTY ARE THE ONLY ONES THAT SUB-ZERO WILL PROVIDE, EITHER UNDER THESE WARRANTIES OR UNDER ANY WARRANTY ARISING BY OPERATION OF LAW. SUB-ZERO WILL NOT BE RESPONSIBLE FOR ANY CONSEQUENTIAL OR INCIDENTAL DAMAGES ARISING FROM THE BREACH OF THESE WARRANTIES OR ANY OTHER WARRANTIES, WHETHER EXPRESS, IMPLIED OR STATUTORY.**

Some states do not allow the exclusion or limitation of incidental or consequential damages, so the above limitation or exclusion may not apply to you. This warranty gives you specific legal rights and you may also have other legal rights, which vary from state to state.

To receive parts and/or service and the name of the Sub-Zero authorized service center nearest you, contact your Sub-Zero dealer, distributor or Sub-Zero Freezer Company, Customer Service Department, P.O. Box 44130, Madison Wisconsin, 53744-4130; call 800-222-7820; or e-mail us at customerservice@subzero.com.

\* Stainless Steel (classic, platinum and carbon) doors, panels, product frames and stainless interior surfaces are covered by a limited 60 day parts and labor warranty for cosmetic defects.

\* Replacement water filter cartridges are not covered by the product warranty.



**PRO  
48**

SUB-ZERO FREEZER COMPANY, INC. P. O. BOX 44130 MADISON, WI 53744-4130 800-222-7820 SUBZERO.COM

