

*Frigidaire*

Factory Parts Catalog

Product No.	FFU12F2HW0
Series	134A
Color	white
Volts	115
Wiring Diagram	297010001
Owner's Guide	297080400
Market	North America
Energy Guide	297221301



Electrolux Major Appliances  
North & Latin America  
P.O. BOX 212378  
AUGUSTA, GA 30917

Publication No.  
**5995507133**  
08/02/18  
(EN/SERVICE/MLR)  
365

**UPRIGHT FREEZER**

Model No.  
**FFU12F2HW**

Copyright © 2008 Electrolux Home Products, Inc.  
All rights reserved.

DOOR

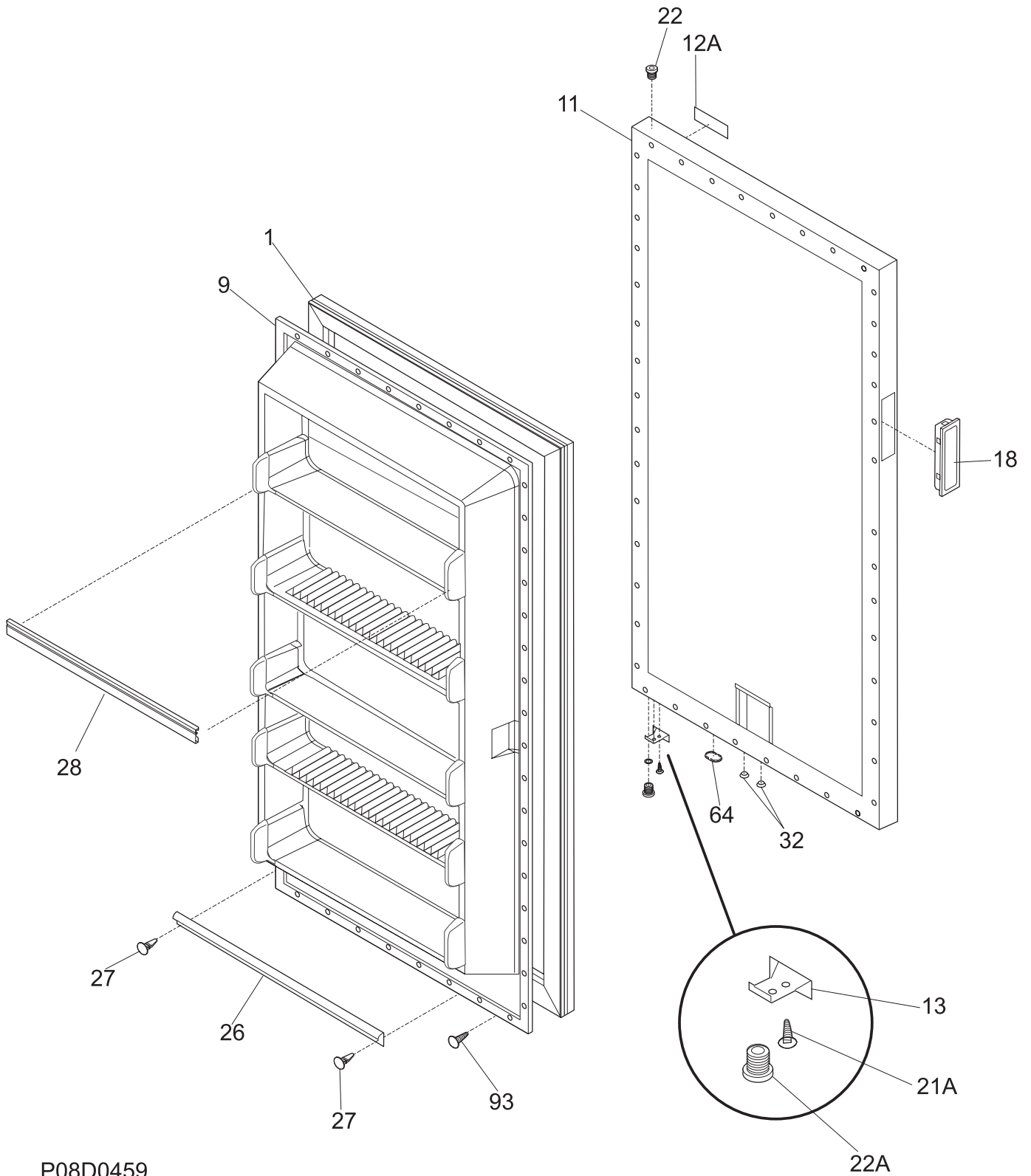

P08D0459

---

**DOOR**

---

POS. NO	PART NO.	DESCRIPTION
1	216522306	Gasket, door seal, white
9	216527617	Panel-inner door, frzr
11	216557850	Panel-outer door, white
12A	216892802	Nameplate
13	08016354	Door Stop
18	297034200	Handle, recessed, white, incl/gasket
21A	5304464375	Screw, door stop mtg, 4.0 x 0.7-19.7, flat hd, metric
22	216970800	Bearing, hinge w/o'ring, top
22A	297006800	Bearing-hinge, btm, w/o'ring
26	216524300	Gasket, secondary
27	5303212828	Clip, panel mtg
27*	5304406520	Clip, panel mtg kit, (40)
28	216951601	Rack-door, (5)
32	5309950074	Valve, breather
64	216403700	Plug-button, hole filler, door base
93	5304460605	Screw, ph truss head, 8-18AB x 0.500

CABINET

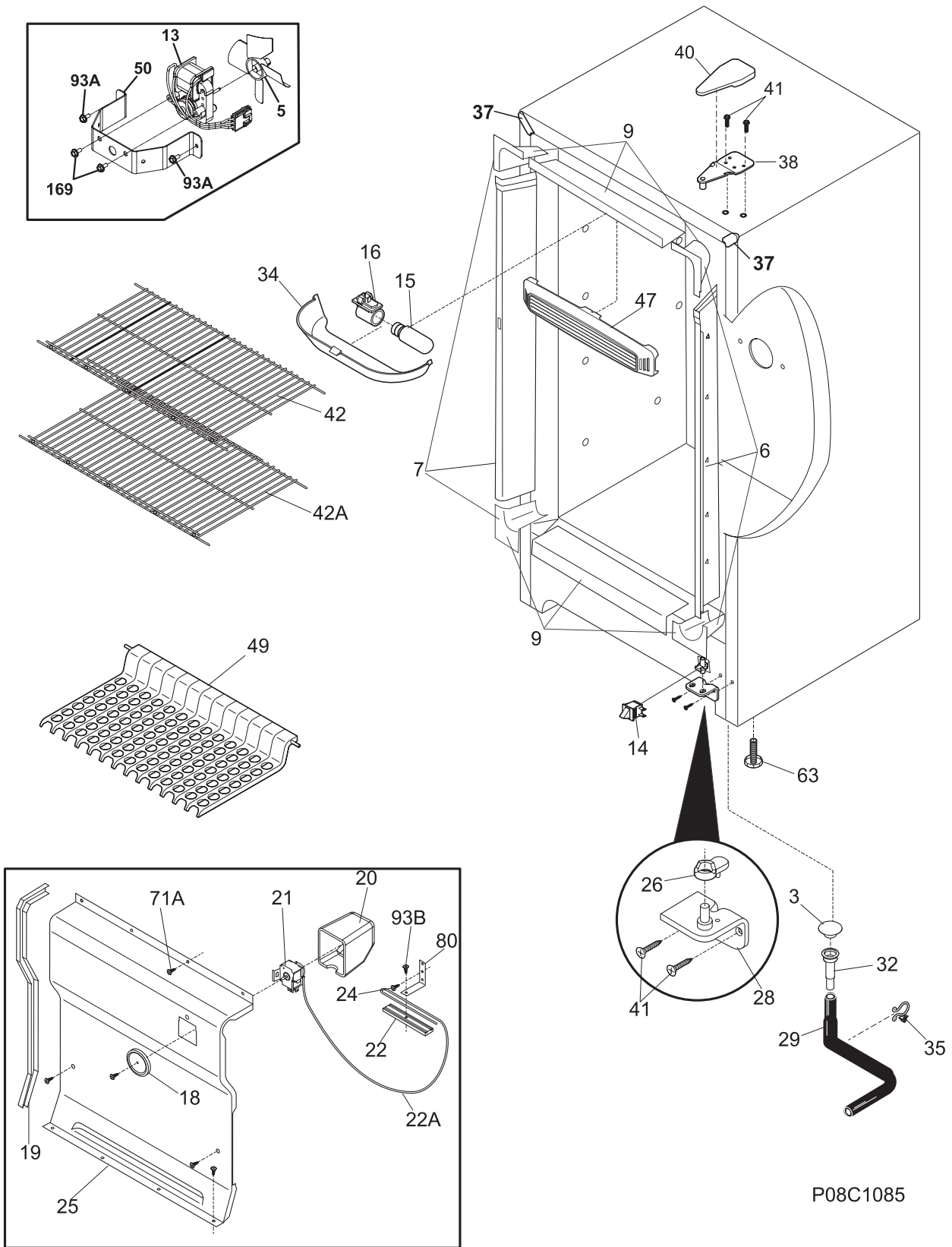

## CABINET

---

POS. NO	PART NO.	DESCRIPTION
3	216503100	Screen-drain
5 #	216325600	Fan Blade
6	297200300	Breaker Kit w/corners, no lock slot
9	297200200	Breaker Kit w/corners, 28", top and bottom
13	216934100	Motor, fan, 115 V
14	216998000	Switch, light/lamp, ramp
15	216846400	Light Bulb/Lamp
16	216817600	Socket, light/lamp, 25 W
18	216707200	Knob, temp control
19	216204900	Gasket, evap cover
20	216967200	Cover, temp control
21 #	216788000	Control, temperature
22	216823500	Clamp, cap tube, cold control
22A	5303916855	Tube, sensor sleeve, plastic, clear
24	5304460604	Screw, type A, 10-24 x 3/8
25	297098600	Cover-evaporator
26	216503300	Ramp, door closer
28	297164500	Hinge-bottom, stepped pin
29	216313504	Hose-drain
32	5308005500	Drain
34	297184400	Shield-light
35	216273000	Clip, drain hose
37	241611301	Trim-cabinet corner, white, (2)
38	297164300	Hinge-upper
40	297164400	Cover-hinge
41	240578902	Screw, hex head, 1/4-20 x 5/8
42	297120000	Shelf, 12.50x23.88, white
42A	297119900	Shelf, 14.50 X 23.88, white, (2)
*	216502400	Grommet-shelf mtg
47	297192900	Baffle, air
49	216937600	Trivet
50	216394050	Bracket, fan motor mount
63	216396900	Screw, leveling foot, plastic, adjustable
71A	297146800	Screw, 8-18AB x 0.470, EVAP PANEL
80	06594601	Bracket, control
93A	216629601	Screw, hex washer head, 10-16 x 0.500, tapping
93B	216036601	Screw, RWHD, 8-32A x 0.500, GX-CA
169	216912401	Screw, hex washer head, 8-32 x 0.500, bracket fan mtr, (2)
*	297001704	Insulation, 24", drain tube
*	5303305324	Paint, touch-up, white
*	297221301	Energy Guide



---

**SYSTEM**

---

POS. NO	PART NO.	DESCRIPTION
1 #	5300123788	Condenser
2	5308000110	Strap-evap/heater, aluminum, (2)
4	216987500	Drier-filter
5 #	297172200	Harness-main
5*	240555002	Screw-#8-32 X 3/8
14	216740000	Heater-defrost
15 #	216997200	Evaporator
15A	216565700	Heat Exchanger
18	297078700	Insulator-evap, styrofoam
19	297078800	Insulator-evap, styrofoam
20	216872200	Thermostat, defrost
23 #	216744500	Timer-defrost
24	216968501	Bracket-timer
27	5308002681	Grommet, compressor
29 #	297054400	Compressor, assy, w/electricals
30 #	297054500	Relay Combo
31A	216948700	Pan-drain
*	5304455846	Clamp, .31 ID, steel, water tube
35	297177200	Bolt, compressor, (4)
43B	297048400	Clip
86	216036601	Screw, RWHD, 8-32A x 0.500, GX-CA
87	5304463290	Screw, hi-lo blunt, #8-18X1/2, timer bracket
130	216486800	Support, evaporator mtg
* #	216502500	Sleeve, suction line
*	297014500	Plug-suction line
* #	297169900	Cord-power, flat