

Integrated Electric Cooktop

MODEL CT15E/S

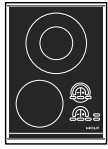

Model CT15E/S
Classic Stainless Steel

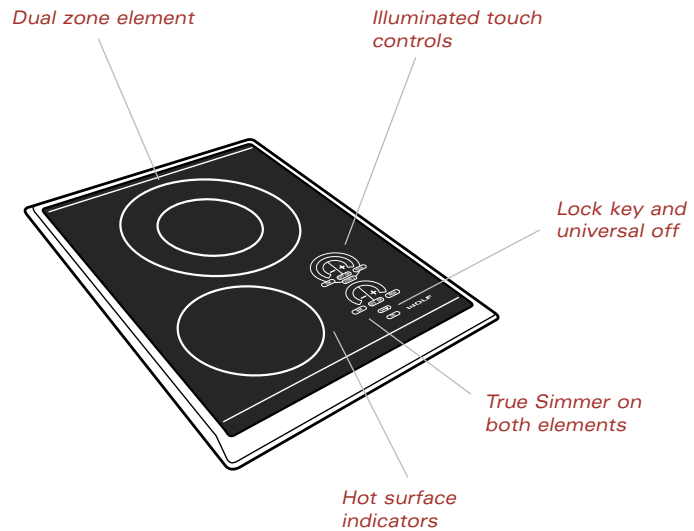

► The Wolf Model CT15E/S 15" (381) framed electric cooktop is available with classic stainless steel trim finish.



This appliance is certified by Star-K to meet strict religious regulations in conjunction with specific instructions found on www.star-k.org.

Behind the sophisticated, minimalist exterior, beneath that perfectly smooth, subtly patterned glass that cleverly reduces scratches, there is a high-performance cooking tool.

The black ceramic glass top is beautifully complemented by the classic stainless steel trim finish.

Two cooking elements with three temperature zones offers exceptional control of temperature for a variety of size pans. Both heating elements offer True Simmer along with one element that enables you to set a temperature for melting.

Let Wolf, the corporate companion and kitchen soul mate of Sub-Zero, fuel your passion for cooking and kitchen design.

Integrated Electric Cooktop

MODEL CT15E/S

FEATURES

- ▶ Integrated design allows for use with multiple cooktop units
- ▶ Classic stainless steel trim finish
- ▶ Easy to clean black ceramic glass surface is resistance to scratching, staining, impact and heat – translucent surface allows you to see the glow of hot elements
- ▶ Illuminated touch controls with graduated control lighting
- ▶ Two ribbon-type radiant heating elements with dual temperature zones on one element
- ▶ True Simmer setting on both elements
- ▶ Melt setting on single element
- ▶ Hot surface indicators on both elements
- ▶ Fast power cycles eliminate long durations of on/off cycles used to control cooking temperature
- ▶ Temperature limiter to ensure that safe operating temperature of glass ceramic is never exceeded
- ▶ Child safety lock key and universal off
- ▶ Certified by Star-K to meet religious regulations
- ▶ CSA certified for US and Canada
- ▶ Two and five year residential warranty – exclusions apply, see warranty at the end of this guide

OVERALL DIMENSIONS ▼

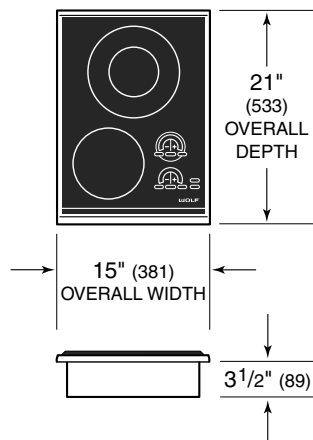

- ▶ Dimensions may vary by $\pm 1/8$ " (3).
- ▶ Dimensions in parentheses are in millimeters unless otherwise specified.

Integrated Electric Cooktop

MODEL CT15E/S



Model CT15E/S
Classic Stainless Steel

TRIM FINISH

Classic Stainless Steel CT15E/S

VENTILATION OPTIONS

- ▶ Chimney Wall or Island Hood
- ▶ Downdraft Ventilation System
- ▶ Pro Series Wall or Island Hood

Refer to the Wolf Cooktop Ventilation or Pro Series Ventilation sections for additional information.

ACCESSORIES

- ▶ Filler strip

Contact your Wolf dealer for additional information on accessories.

SPECIFICATIONS

Overall Cooktop Width	15" (381)
Overall Cooktop Height	3 ¹ / ₂ " (89)
Overall Cooktop Depth	21" (533)
Cooktop Cut-out Width	13 ³ / ₈ " (340)
Cooktop Cut-out Depth	19 ¹ / ₄ " (489)
Minimum Cabinet Depth	22 ³ / ₄ " (578)

Two Heating Elements with Three Zones

Dual zone element power (max) –
2,200W outer / 750W inner
Single zone element power (max) – 1,200W

Electrical Supply Requirements	240 V AC, 60 Hz, 15 amp dedicated circuit
Conduit	4 ft (1.2 m) flexible 3-wire
Total Connected Load	3.4 Kw at 240 V 2.6 Kw at 208 V

Shipping Weight 30 lbs (14 kg)

Special Note Cooktop can be installed
in combination with other cooktops

- ▶ Specifications are subject to change without notice.

▶ Dimensions in parentheses are in millimeters unless otherwise specified.

Integrated Electric Cooktop

INSTALLATION

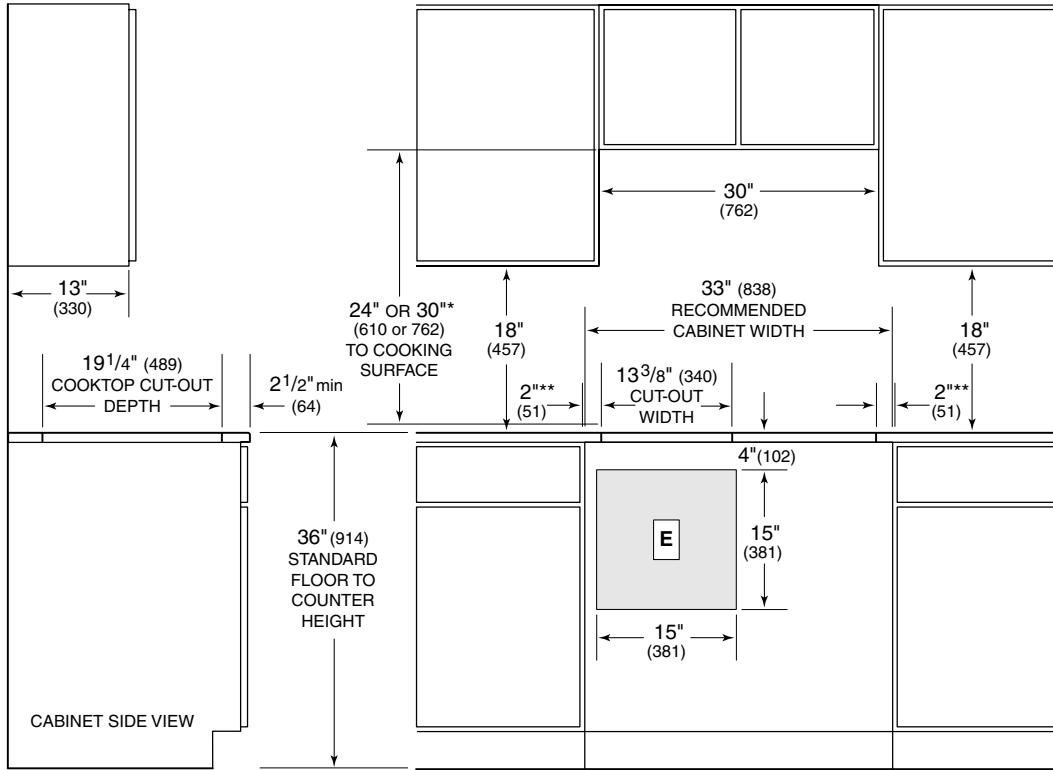

NOTE: Application shown allows for installation of two 15" (381) modules side-by-side.

* Minimum 24" (610) from protected cabinet or 30" (762) from unprotected cabinet to cooking surface.

** Minimum clearance from side edge of cooktop cut-out to combustible surface up to 18" (457) above cooking surface.

► Dimensions may vary by $\pm 1/8"$ (3).

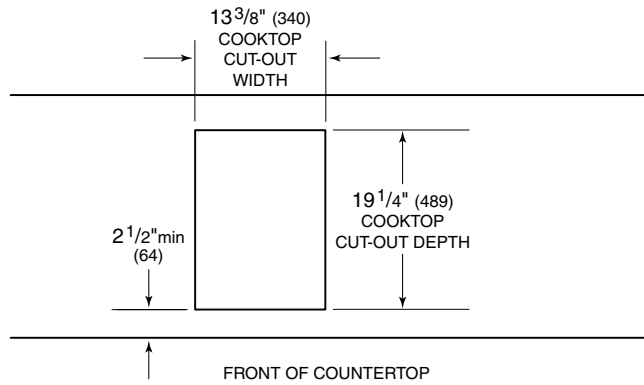

DIMENSIONS

Cooktop Cut-Out Width	13 ³ / ₈ " (340)
Recommended Cabinet Width	33" (838)
Cooktop Cut-Out Depth	19 ¹ / ₄ " (489)
Location of Electrical	Within shaded area

► See Installation Instructions shipped with unit for detailed specifications.

► Dimensions in parentheses are in millimeters unless otherwise specified.

Integrated Electric Cooktop

INSTALLATION

INSTALLATION NOTES

IMPORTANT NOTE: Review specific installation instructions for product to product capabilities

- ▶ Wolf recommends using 33" (838) cabinets with the 15" (381) framed electric cooktop.
- ▶ If the 15" (381) framed electric cooktop is to be used with any combination of additional cooktop units or modules with a filler strip, the cut-out width increases to 14" (356). When multiple 15" (381) modules are installed side-by-side refer to the General Applications section for additional information.
- ▶ The Wolf 15" (381) framed electric cooktop requires a separate, grounded 4-wire 240V, 15 amp service with its own circuit breaker. It has a 4' (1.2 m) flexible 3-wire conduit for connection at the electrical supply. Locate electrical within the shaded area shown in the illustration.

▶ You must follow all National Electrical Code regulations. In addition, be aware of local codes and ordinances when installing your service.

▶ A Wolf ventilation system is recommended. When installing a ventilation hood, refer to the specific requirements of the hood for the minimum dimension to cooking surface.

▲ WARNING

This cooktop is intended for indoor use.

▶ *Dimensions in parentheses are in millimeters unless otherwise specified.*

Integrated Electric Grill Cooktop

MODEL IG15/S



Model IG15/S
Classic Stainless Steel

Low profile one piece
grilling grate

Two 1,400 watt
heating elements

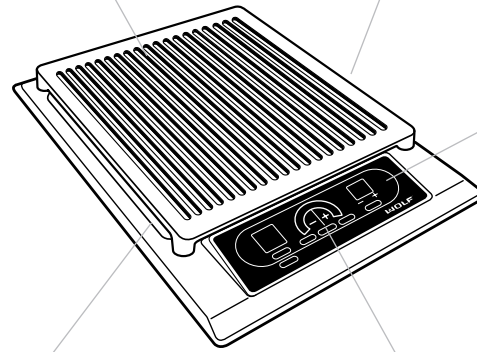

Illuminated touch
controls

Removable
collection pan

Graduated
control lighting

► The Wolf Model IG15/S 15" (381) electric grill cooktop is available in the classic stainless steel finish.



This appliance is certified by Star-K to meet strict religious regulations in conjunction with specific instructions found on www.star-k.org.

Who says you have to sacrifice the fun of grilling when the weather changes and you cannot take advantage of the outdoors? With this grill cooktop you can easily handle steaks and all sorts of food without the hassle of lava rocks or briquettes.

There are two 1,400 watt heating elements – front and back – on this 15" (381) unit that enables you to cook on one side of the cooktop while keeping other items at serving temperature.

For ease of cleaning, there are porcelain plates below the heating elements that accumulate any unwanted grease and drain it to the removable porcelain collection pan.

Let Wolf, the corporate companion and kitchen soul mate of Sub-Zero, fuel your passion for cooking and kitchen design.

Integrated Electric Grill Cooktop

MODEL IG15/S - SPECIFICATIONS

FEATURES

- ▶ Integrated design allows for use with multiple cooktop units
- ▶ Stainless steel top construction with classic stainless steel finish
- ▶ Two 1,400 watt individually controlled heating elements – front and back for even grilling
- ▶ Illuminated touch controls with graduated control lighting
- ▶ Low profile, one piece cast iron grilling grate with matte porcelain finish
- ▶ Black porcelain-coated grease deflection plates
- ▶ Easy to clean, removable porcelain collection pan
- ▶ Independent digital timer
- ▶ Certified by Star-K to meet religious regulations
- ▶ CSA certified for US and Canada
- ▶ Two and five year residential warranty – exclusions apply, see warranty at the end of this guide

OVERALL DIMENSIONS ▼

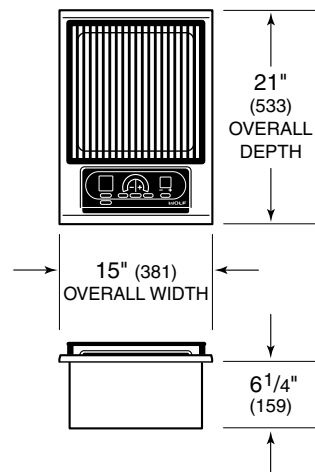

- ▶ Dimensions may vary by $\pm 1/8$ " (3).
- ▶ Dimensions in parentheses are in millimeters unless otherwise specified.

Integrated Electric Grill Cooktop

MODEL IG15/S - SPECIFICATIONS

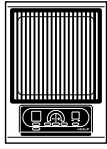

Model IG15/S
Classic Stainless Steel

TRIM FINISH ▼

Classic Stainless Steel IG15/S

VENTILATION OPTIONS

- ▶ Chimney Wall or Island Hood
- ▶ Downdraft Ventilation System
- ▶ Pro Series Wall or Island Hood

Refer to the Wolf Cooktop Ventilation or Pro Series Ventilation sections for additional information.

ACCESSORIES

- ▶ Set on griddle
- ▶ Filler strip

Contact your Wolf dealer for additional information on accessories.

SPECIFICATIONS ▼

Overall Cooktop Width	15" (381)
Overall Cooktop Height	6 1/4" (159)
Overall Cooktop Depth	21" (533)
Cooktop Cut-out Width	14" (356)
Cooktop Cut-out Depth	19 1/4" (489)
Minimum Cabinet Depth	22 3/4" (578)
Two Heating Elements	1,400 W each
Electrical Supply Requirements	240 V AC, 60 Hz, 15 amp dedicated circuit
Conduit	4 ft (1.2 m) flexible 3-wire
Total Connected Load	2.8 Kw at 240 V
Total Amps	12
Shipping Weight	50 lbs (23 kg)
Special Note	Cooktop can be installed in combination with other cooktops

- ▶ Specifications are subject to change without notice.

▶ Dimensions in parentheses are in millimeters unless otherwise specified.

Integrated Electric Grill Cooktop

INSTALLATION

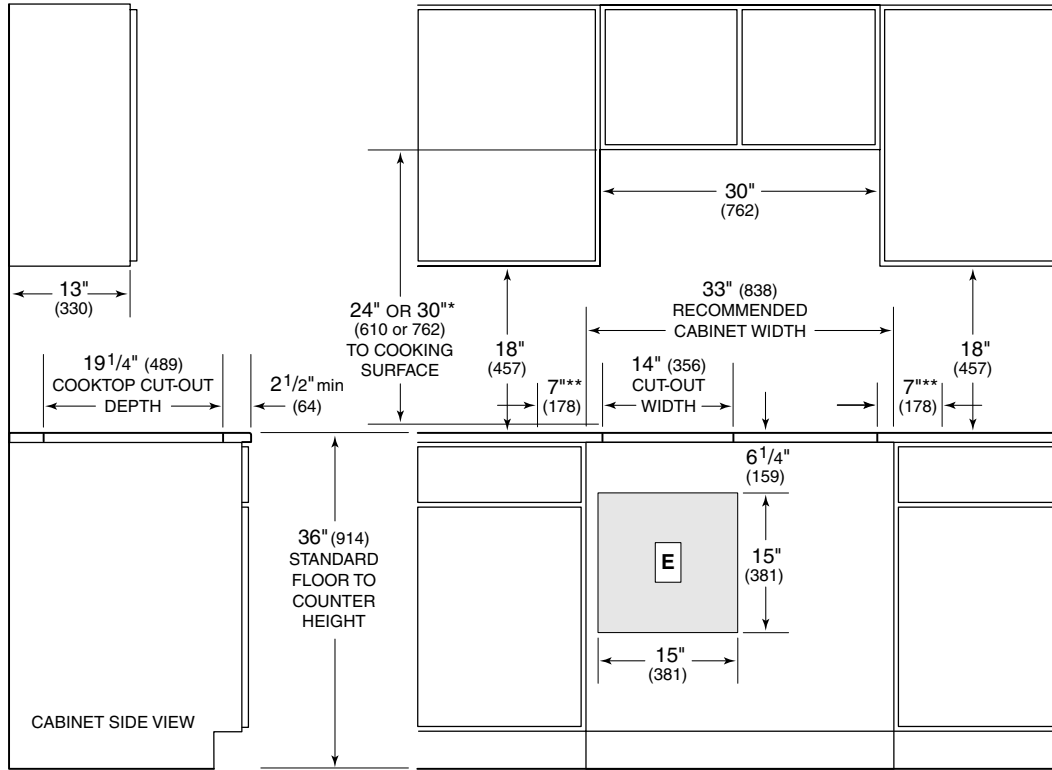

NOTE: Application shown allows for installation of two 15" (381) modules side-by-side.

* Minimum 24" (610) from protected cabinet or 30" (762) from unprotected cabinet to cooking surface.

** Minimum clearance from side edge of cooktop cut-out to combustible surface up to 18" (457) above cooking surface.

► Dimensions may vary by $\pm 1/8"$ (3).

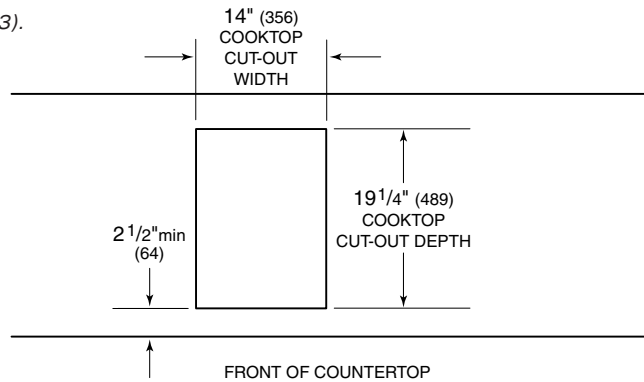

DIMENSIONS

Cooktop Cut-Out Width	14" (356)
Recommended Cabinet Width	33" (838)
Cooktop Cut-Out Depth	19 1/4" (489)
Location of Electrical	Within shaded area

► See Installation Instructions shipped with unit for detailed specifications.

► Dimensions in parentheses are in millimeters unless otherwise specified.

Integrated Electric Grill Cooktop

INSTALLATION

INSTALLATION NOTES

IMPORTANT NOTE: Review specific installation instructions for product to product capabilities

- ▶ Wolf recommends using 33" (838) cabinets with the 15" (381) cooktop.
- ▶ When multiple 15" (381) cooktop modules are installed side-by-side refer to the General Applications section for additional information.
- ▶ The Wolf electric grill cooktop requires a separate, grounded 4-wire 240V, 15 amp service with its own circuit breaker. The unit is provided with a 4' (1.2 m) flexible 3-wire conduit for connection at the electrical supply. Locate electrical within the shaded area shown in the illustration.

▶ You must follow all National Electrical Code regulations. In addition, be aware of local codes and ordinances when installing your service.

▶ A Wolf ventilation system is recommended. When installing a ventilation hood, refer to the specific requirements of the hood for the minimum dimension to cooking surface.

⚠ WARNING

This cooktop is intended for indoor use.

▶ *Dimensions in parentheses are in millimeters unless otherwise specified.*

Integrated Electric Steamer Cooktop

MODEL IS15/S

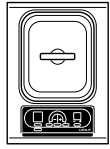

Model IS15/S
Classic Stainless Steel

Reversible domed
glass lid

Hidden 2,600 watt
heating element

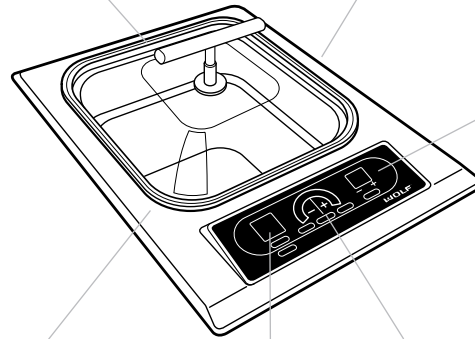

Illuminated touch
controls

Deep drawn pan

Graduated
control lighting

Digital temperature
readout

► The Wolf Model IS15/S 15" (381) electric steamer cooktop is available in the classic stainless steel finish.



This appliance is certified by Star-K to meet strict religious regulations in conjunction with specific instructions found on www.star-k.org.

From a temperature of 140°F (60°C) to boil, you can keep food hot for long periods of time or defrost easily without drying out or losing its flavor.

The beauty of this cooktop module is accented by the sculptured glass domed lid, which is easily inverted for storage to keep a low profile.

The deep, large vessel with a two gallon (7.6 L) capacity can hold up to 14 cups of cooked pasta. Includes one solid and one perforated stackable insert pan.

The Wolf steamer cooktop is available in classic stainless steel.

Let Wolf, the corporate companion and kitchen soul mate of Sub-Zero, fuel your passion for cooking and kitchen design.

Integrated Electric Steamer Cooktop

MODEL IS15/S - SPECIFICATIONS

FEATURES

- ▶ Integrated design allows for use with multiple cooktop units
- ▶ Stainless steel top construction with classic stainless steel finish
- ▶ Hidden 2,600 watt heating element
- ▶ Illuminated touch controls with graduated control lighting
- ▶ Large two gallon (7.6 L) maximum capacity tub - 10 cup capacity for steaming
- ▶ Two stackable stainless steel steamer insert pans - one solid and one perforated
- ▶ Reversible domed glass lid for easy storage
- ▶ Independent digital timer
- ▶ Digital temperature readout and preheat indicator
- ▶ Electronic drain
- ▶ Certified by Star-K to meet religious regulations
- ▶ CSA certified for US and Canada
- ▶ Two and five year residential warranty - exclusions apply, see warranty at the end of this guide

OVERALL DIMENSIONS ▼

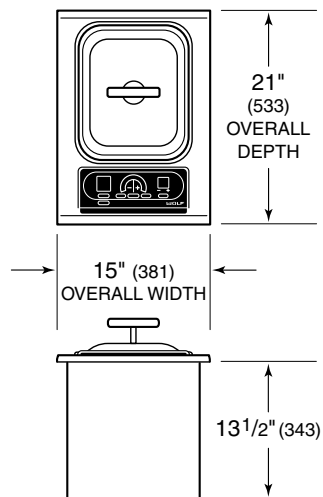

- ▶ Dimensions may vary by $\pm 1/8"$ (3).
- ▶ Dimensions in parentheses are in millimeters unless otherwise specified.

Integrated Electric Steamer Cooktop

MODEL IS15/S - SPECIFICATIONS

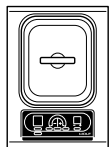

Model IS15/S
Classic Stainless Steel

TRIM FINISH

Classic Stainless Steel IS15/S

VENTILATION OPTIONS

- ▶ Chimney Wall or Island Hood
- ▶ Pro Series Wall or Island Hood

Refer to the Wolf Cooktop Ventilation or Pro Series Ventilation sections for additional information.

ACCESSORIES

- ▶ Perforated pan for stacked cooking
- ▶ Filler strip

Contact your Wolf dealer for additional information on accessories.

SPECIFICATIONS

Overall Cooktop Width	15" (381)
Overall Cooktop Height	13 ¹ / ₂ " (343)
Overall Cooktop Depth	21" (533)
Cooktop Cut-out Width	14" (356)
Cooktop Cut-out Depth	19 ¹ / ₄ " (489)
Minimum Cabinet Depth	22 ³ / ₄ " (578)
Heating Element	2,600W
Electrical Supply Requirements	240 V AC, 60 Hz, 15 amp dedicated circuit
Conduit	4 ft (1.2 m) flexible 3-wire
Total Connected Load	2.6 Kw at 240 V
Shipping Weight	40 lbs (18 kg)
Special Note	Cooktop can be installed in combination with other cooktops

- ▶ Specifications are subject to change without notice.

▶ Dimensions in parentheses are in millimeters unless otherwise specified.

Integrated Electric Steamer Cooktop

INSTALLATION

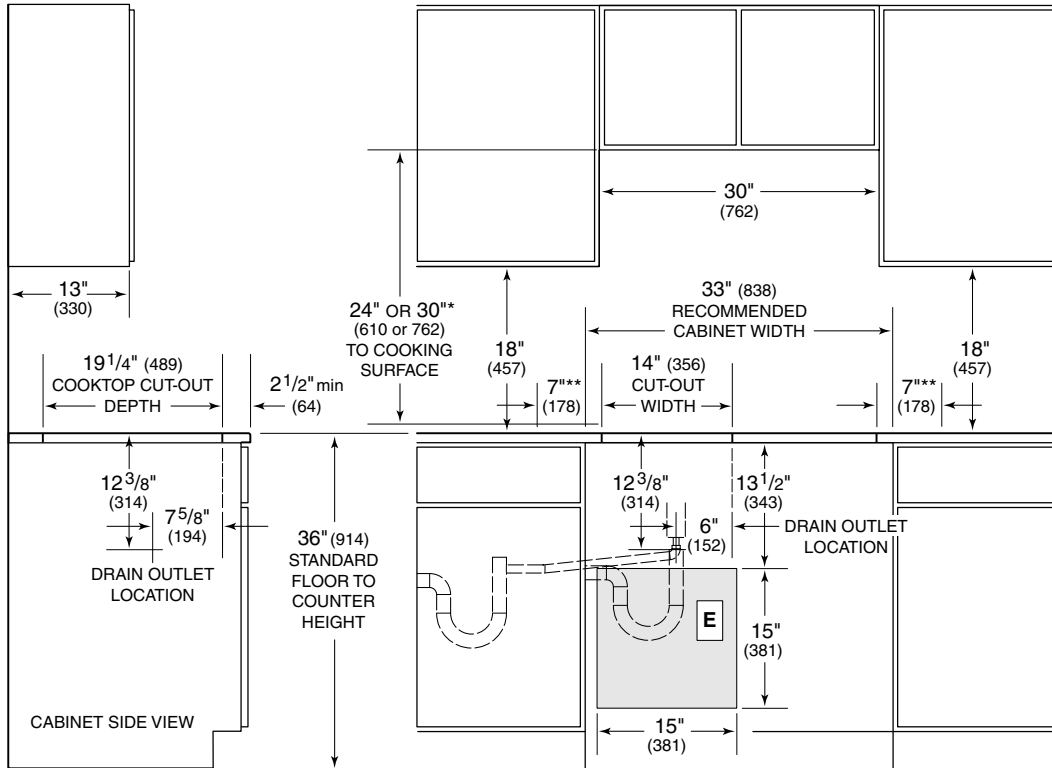

NOTE: Application shown allows for installation of two 15" (381) modules side-by-side.

* Minimum 24" (610) from protected cabinet or 30" (762) from unprotected cabinet to cooking surface.

** Minimum clearance from side edge of cooktop cut-out to combustible surface up to 18" (457) above cooking surface.

► Dimensions may vary by $\pm 1/8"$ (3).

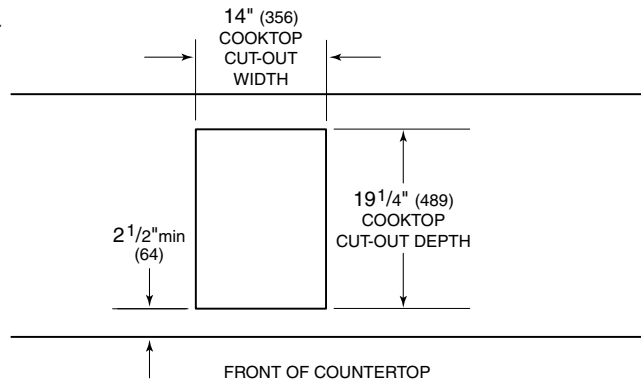

DIMENSIONS

Cooktop Cut-Out Width	14" (356)
Recommended Cabinet Width	33" (838)
Cooktop Cut-Out Depth	19 1/4" (489)
Location of Electrical	Within shaded area

► See Installation Instructions shipped with unit for detailed specifications.

► Dimensions in parentheses are in millimeters unless otherwise specified.

Integrated Electric Steamer Cooktop

INSTALLATION

INSTALLATION NOTES

IMPORTANT NOTE: Review specific installation instructions for product to product capabilities

- ▶ Wolf recommends using 33" (838) cabinets with the 15" (381) cooktop.
- ▶ When multiple 15" (381) cooktop modules are installed side-by-side refer to the General Applications section for additional information.

▲ WARNING

This cooktop should not be installed immediately next to a Wolf 15" (381) fryer cooktop, as contact between water and hot oil may cause burns from steam and hot oil.

- ▶ The Wolf electric steamer cooktop requires a separate, grounded 3-wire 240V, 15 amp service with its own circuit breaker. The unit is provided with a 4' (1.2 m) flexible 3-wire conduit for connection at the electrical supply. Locate electrical within the shaded area shown in the illustration.
- ▶ You must follow all National Electrical Code regulations. In addition, be aware of local codes and ordinances when installing your service.

- ▶ You must follow all National Electrical Code regulations. In addition, be aware of local codes and ordinances when installing your service.

- ▶ For the drain connection, the 5/8" (16) outlet from the valve will accept a drain hose that must flow downward to and tie into an existing sink drain. Or a separate drain with a freefall may be installed. Following local building codes, your plumber will dictate how to plumb the unit. As a third option, the consumer will supply a heat resistant bucket for drainage in the location of the drain outlet. Refer to the illustration for location of the drain outlet.

- ▶ A Wolf ventilation system is recommended. When installing a ventilation hood, refer to the specific requirements of the hood for the minimum dimension to cooking surface.

▲ WARNING

This cooktop is intended for indoor use.

▶ Dimensions in parentheses are in millimeters unless otherwise specified.

Integrated Electric Fryer Cooktop

MODEL IF15/S

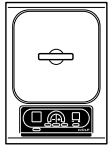

*Model IF15/S
Classic Stainless Steel*

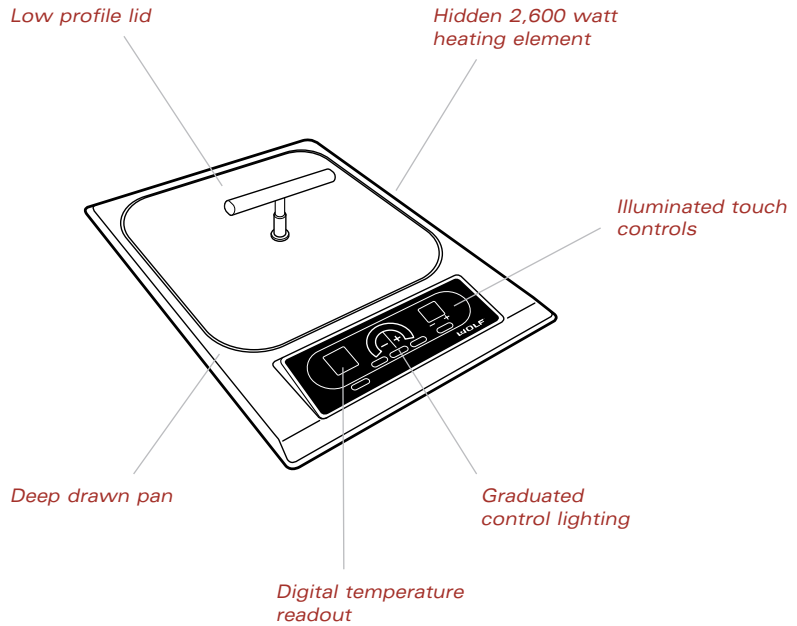

► *The Wolf Model IF15/S 15" (381) electric fryer cooktop is available in the classic stainless steel finish.*

To round out your options for the ideal kitchen, you must have a fryer to choose from and Wolf offers a great option that the market has never seen. Dinner specialties that you never tried before will be at your fingertips when your client uses this module.

The accurate temperature control will enable your customer to seal in that great flavor of the food without absorbing any unnecessary grease. In addition the extremely deep fryer will enable you to handle large portions of small items or a whole chicken.

Let Wolf, the corporate companion and kitchen soul mate of Sub-Zero, fuel your passion for cooking and kitchen design.

Integrated Electric Fryer Cooktop

MODEL IF15/S - SPECIFICATIONS

FEATURES

- ▶ Integrated design allows for use with multiple cooktop units
- ▶ Stainless steel top construction with classic stainless steel finish
- ▶ Hidden 2,600 watt heating element
- ▶ Illuminated touch controls with graduated control lighting
- ▶ Large 1-1/4 gallon (3.8 L) capacity tub
- ▶ Three baskets included – one large and two small side by side, each with wire basket hanger
- ▶ Low profile lid
- ▶ Melt feature
- ▶ Independent digital timer
- ▶ Digital temperature readout and preheat indicator
- ▶ Easy manual locking drain capability
- ▶ CSA certified for US and Canada
- ▶ Two and five year residential warranty – exclusions apply, see warranty at the end of this guide

OVERALL DIMENSIONS ▼

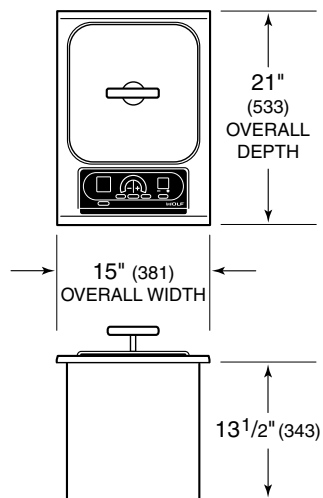

- ▶ Dimensions may vary by $\pm 1/8"$ (3).
- ▶ Dimensions in parentheses are in millimeters unless otherwise specified.

Integrated Electric Fryer Cooktop

MODEL IF15/S - SPECIFICATIONS

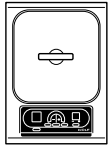

Model IF15/S
Classic Stainless Steel

TRIM FINISH

Classic Stainless Steel IF15/S

VENTILATION OPTIONS

- ▶ Chimney Wall or Island Hood
- ▶ Pro Series Wall or Island Hood

Refer to the Wolf Cooktop Ventilation or Pro Series Ventilation sections for additional information.

ACCESSORIES

- ▶ Filler strip

Contact your Wolf dealer for additional information on accessories.

SPECIFICATIONS

Overall Cooktop Width	15" (381)
Overall Cooktop Height	13 ¹ / ₂ " (343)
Overall Cooktop Depth	21" (533)
Cooktop Cut-out Width	14" (356)
Cooktop Cut-out Depth	19 ¹ / ₄ " (489)
Minimum Cabinet Depth	22 ³ / ₄ " (578)
Heating Element	2,600W
Electrical Supply Requirements	240 V AC, 60 Hz, 15 amp dedicated circuit
Conduit	4 ft (1.2 m) flexible 3-wire
Total Connected Load	2.6 Kw at 240 V
Shipping Weight	30 lbs (14 kg)
Special Note	Cooktop can be installed in combination with other cooktops

- ▶ Specifications are subject to change without notice.

▶ Dimensions in parentheses are in millimeters unless otherwise specified.

Integrated Electric Fryer Cooktop

INSTALLATION

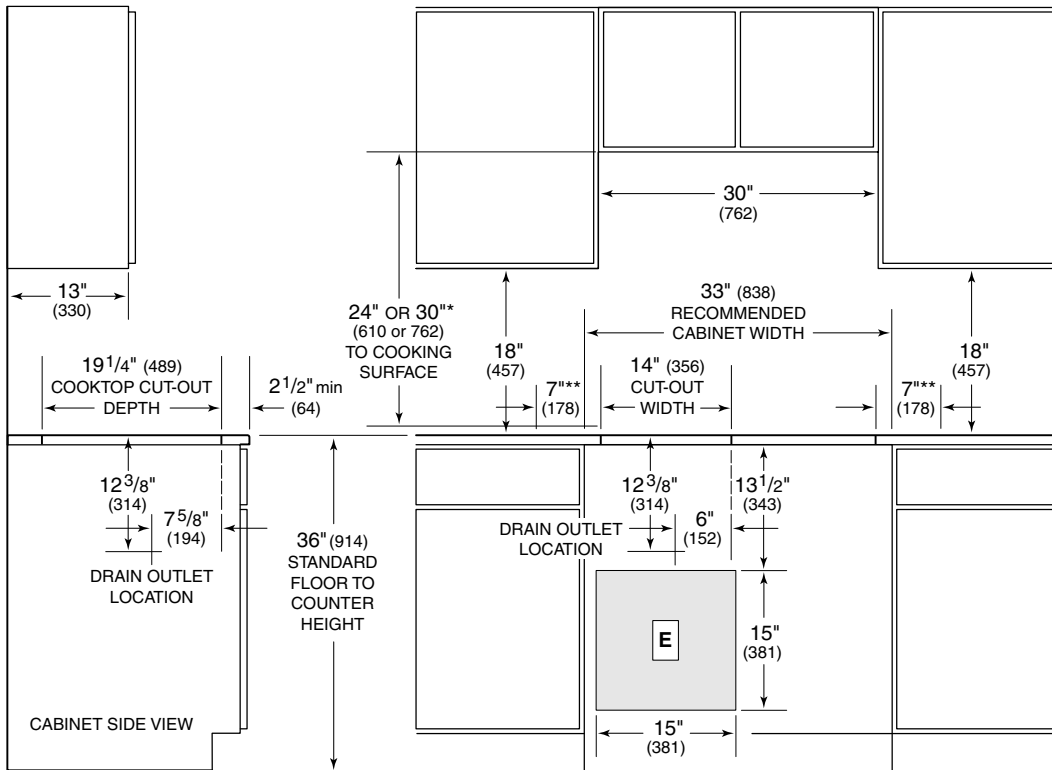

NOTE: Application shown allows for installation of two 15" (381) modules side-by-side.

* Minimum 24" (610) from protected cabinet or 30" (762) from unprotected cabinet to cooking surface.

** Minimum clearance from side edge of cooktop cut-out to combustibile surface up to 18" (457) above cooking surface.

► Dimensions may vary by $\pm 1/8"$ (3).

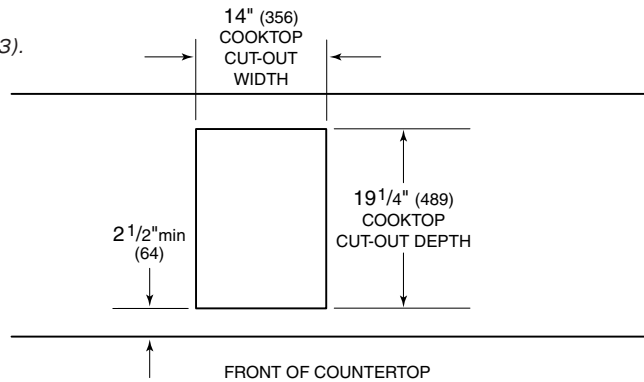

DIMENSIONS

Cooktop Cut-Out Width	14" (356)
Recommended Cabinet Width	33" (838)
Cooktop Cut-Out Depth	19 1/4" (489)
Location of Electrical	Within shaded area

► See Installation Instructions shipped with unit for detailed specifications.

► Dimensions in parentheses are in millimeters unless otherwise specified.

Integrated Electric Fryer Cooktop

INSTALLATION

INSTALLATION NOTES

IMPORTANT NOTE: Review specific installation instructions for product to product capabilities

- ▶ Wolf recommends using 33" (838) cabinets with the 15" (381) cooktop.
- ▶ When multiple 15" (381) cooktop modules are installed side-by-side refer to the General Applications section for additional information.

⚠ WARNING

This cooktop cannot be installed immediately next to any open flame cooking device. The open flame may cause ignition of oil.

- ▶ The Wolf electric fryer cooktop requires a separate, grounded 3-wire 240V, 15 amp service with its own circuit breaker. The unit is provided with a 4' (1.2 m) flexible 3-wire conduit for connection at the electrical supply. Locate electrical within the shaded area shown in the illustration.
- ▶ You must follow all National Electrical Code regulations. In addition, be aware of local codes and ordinances when installing your service.

- ▶ You must follow all National Electrical Code regulations. In addition, be aware of local codes and ordinances when installing your service.

- ▶ The electric fryer cooktop must be installed in a base cabinet with access to the bottom of the unit to drain the oil through a manual valve. The consumer must supply a heat resistant bucket to accept the drained oil. Refer to the illustration for location of the drain outlet.

- ▶ A Wolf ventilation system is recommended. When installing a ventilation hood, refer to the specific requirements of the hood for the minimum dimension to cooking surface.

- ▶ Comprehensive installation instructions are shipped with each Wolf product. Refer to those instructions for detailed specifications.

⚠ WARNING

This cooktop is intended for indoor use.

- ▶ *Dimensions in parentheses are in millimeters unless otherwise specified.*

Integrated Gas Cooktop

MODEL CT15G/S

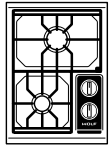

Model CT15G/S
Classic Stainless Steel

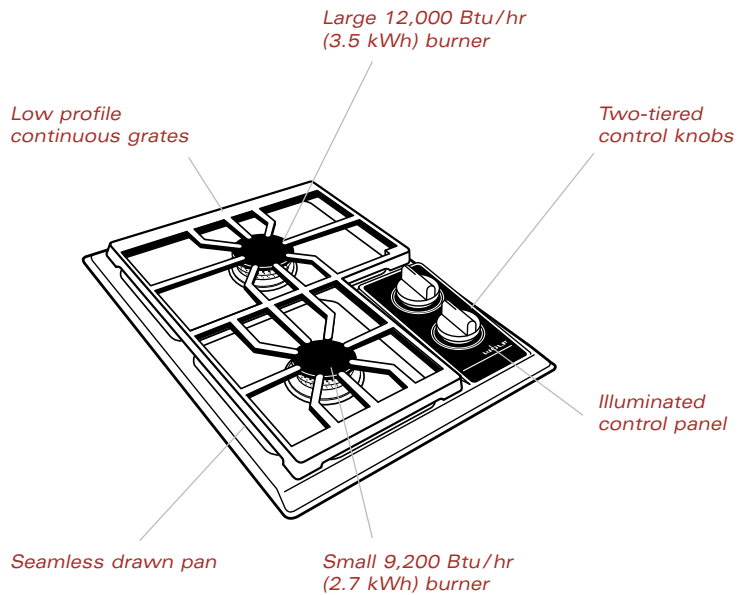

► The Wolf Model CT15G/S 15" (381) gas cooktop is available in natural or LP gas, with classic stainless steel finish. The model number followed by (-LP) denotes an LP gas model.



This appliance is certified by Star-K to meet strict religious regulations in conjunction with specific instructions found on www.star-k.org.

New features make cooking a greater pleasure than ever. For instance, at higher settings the patented Dual Stacked Burner design uses its upper-level burner for maximum heat transfer. Merely turn down the illuminated knob and the lower-tier burners delivers fine-tuning control and True Simmer. This patented feature allows you to have the slightest of flame and enjoy a simmer with no boiling or scorching.

Available in the classic stainless steel finish.

The sealed burners and deep recess of the seamless drawn pan area make clean up of any of those previously unsightly spills a snap.

Let Wolf, the corporate companion and kitchen soul mate of Sub-Zero, fuel your passion for cooking and kitchen design.

Integrated Gas Cooktop

MODEL CT15G/S

FEATURES

- ▶ Integrated design allows for use with multiple cooktop units
- ▶ Available in natural and LP gas
- ▶ Stainless steel top construction with classic stainless steel finish
- ▶ Two automatic electronic re-ignition dual stacked sealed burners
- ▶ One 12,000 Btu/hr (3.5 kWh) sealed burner with 700 Btu/hr (.2 kWh) delivered at simmer
- ▶ One 9,200 Btu/hr (2.7 kWh) sealed burner with 300 Btu/hr (.1 kWh) delivered at simmer
- ▶ Illuminated control panel with two-tiered control knobs
- ▶ True Simmer setting on both burners
- ▶ Individual spark ignition system
- ▶ Low profile cast iron continuous burner grate with matte porcelain finish
- ▶ Seamless drawn burner pan
- ▶ Certified by Star-K to meet religious regulations
- ▶ CSA certified for US and Canada
- ▶ Two and five year residential warranty – exclusions apply, see warranty at the end of this guide

OVERALL DIMENSIONS ▼

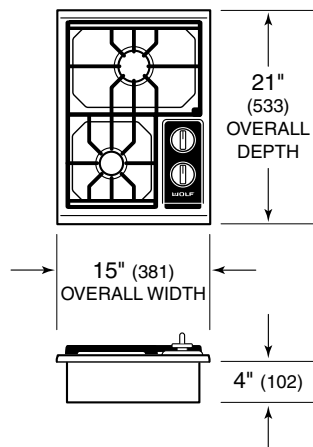

- ▶ Dimensions may vary by $\pm 1/8"$ (3).
- ▶ Dimensions in parentheses are in millimeters unless otherwise specified.

Integrated Gas Cooktop

MODEL CT15G/S

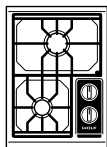

Model CT15G/S
Classic Stainless Steel

TRIM FINISH ▼

Classic Stainless Steel CT15G/S

VENTILATION OPTIONS

- ▶ Chimney Wall or Island Hood
- ▶ Downdraft Ventilation System
- ▶ Pro Series Wall or Island Hood

Refer to the Wolf Cooktop Ventilation or Pro Series Ventilation sections for additional information.

ACCESSORIES

- ▶ Filler strip
- ▶ LP and natural gas conversion kits
- ▶ High altitude conversion kit

Contact your Wolf dealer for additional information on accessories.

SPECIFICATIONS ▼

Overall Cooktop Width	15" (381)
Overall Cooktop Height	4" (102)
Overall Cooktop Depth	21" (533)
Cooktop Cut-out Width	14" (356)
Cooktop Cut-out Depth	19 1/4" (489)
Minimum Cabinet Depth	22 3/4" (578)

Surface Burner Rating
 One 12,000 Btu/hr (3.5 kWh) burner with 700 Btu/hr (.2 kWh) delivered at simmer
 One 9,200 Btu/hr (2.7 kWh) burner with 300 Btu/hr (.1 kWh) delivered at simmer

Gas Rating	21,200 Btu/hr (6.2 kWh)
Electrical Supply Requirements	120 V AC, 60 Hz, 15 amp dedicated circuit

Power Cord	6' (1.8 m) power cord with 3-prong grounded plug
------------	---

Shipping Weight	30 lbs (14 kg)
-----------------	----------------

Special Note Cooktop can be installed
in combination with other cooktops

- ▶ Specifications are subject to change without notice.

▶ Dimensions in parentheses are in millimeters unless otherwise specified.

Integrated Gas Cooktop

INSTALLATION

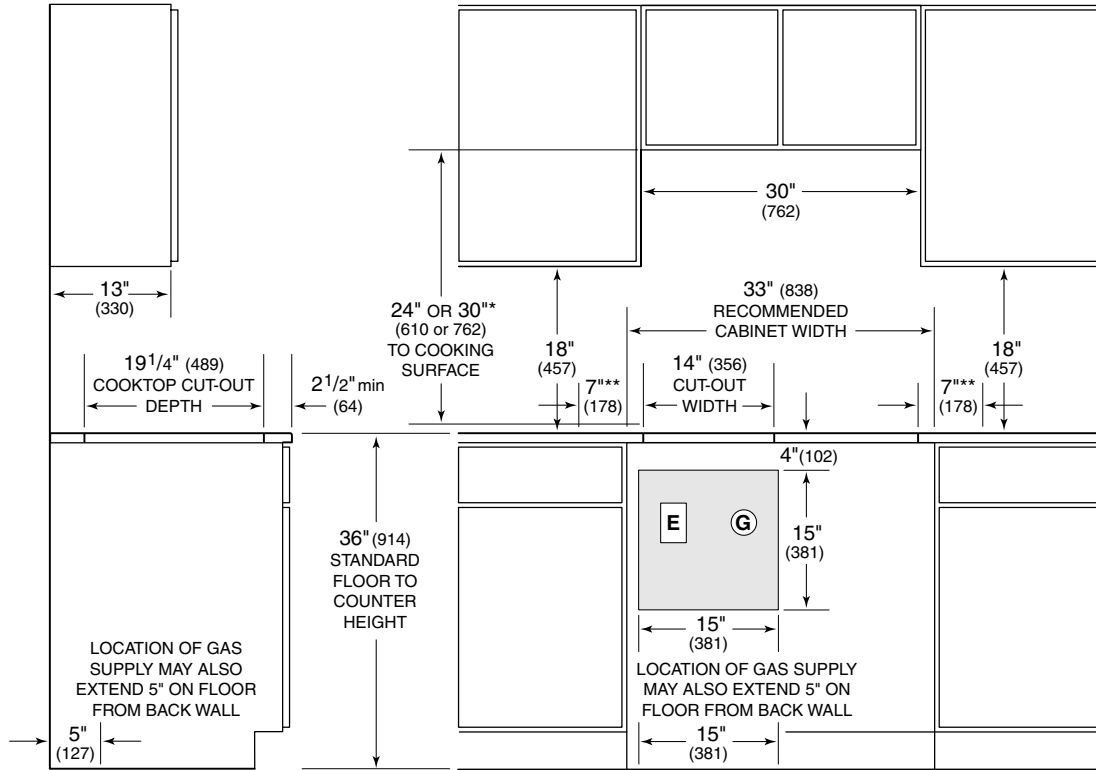

NOTE: Application shown allows for installation of two 15" (381) modules side-by-side.

* Minimum 24" (610) from protected cabinet or 30" (762) from unprotected cabinet to cooking surface.

** Minimum clearance from side edge of cooktop cut-out to combustibles up to 18" (457) above cooking surface.

► Dimensions may vary by $\pm 1/8"$ (3).

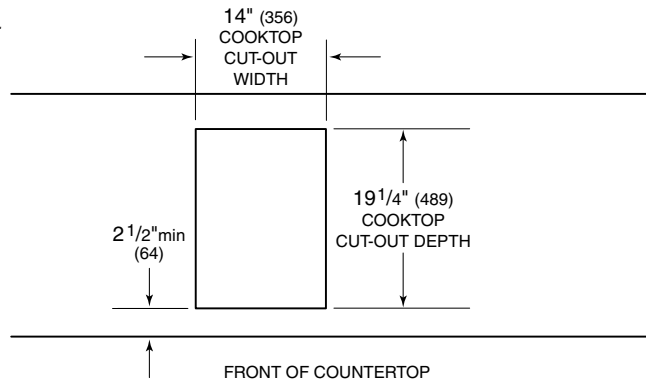

DIMENSIONS

Cooktop Cut-Out Width	14" (356)
Recommended Cabinet Width	33" (838)
Cooktop Cut-Out Depth	19 1/4" (489)
Location of Electrical and Gas Supply	Within shaded area

► See Installation Instructions shipped with unit for detailed specifications.

► Dimensions in parentheses are in millimeters unless otherwise specified.

Integrated Gas Cooktop

INSTALLATION

INSTALLATION NOTES

IMPORTANT NOTE: Review specific installation instructions for product to product capabilities

- ▶ Wolf recommends using 33" (838) cabinets with the 15" (381) cooktop.
- ▶ When multiple 15" (381) cooktop modules are installed side-by-side refer to the General Applications section for additional information.
- ▶ For the 15" (381) gas cooktop, the gas service may be supplied through the floor, if the cooktop is not installed above an oven. Refer to the illustration for specifics on cut-out dimensions and placement of gas and electrical.
- ▶ The Wolf 15" (381) gas cooktop requires a separate 120V, 60 Hz power supply. The service should have its own 15 amp circuit breaker and a grounded 3-prong receptacle should be located within the reach of the 6' (1.8 m) power cord.
- ▶ You must follow all National Electrical Code and gas regulations. In addition, be aware of local codes and ordinances when installing your services.

- ▶ Wolf gas cooktops are designed to operate on natural gas at 5" (127) WC (water column) pressure or LP gas at 10" (254) WC pressure. They are supplied with a 1/2" NPT male gas connection at the right rear corner on the bottom of the cooktop. The male connector exits the unit straight down and you are supplied with a regulator with two female connectors.
- ▶ Wolf gas cooktops using natural gas function up to an altitude of 8,000' (2438 m) without any adjustment. Natural gas installations from 8,000' (2438 m) to 10,000' (3048 m) need the high altitude conversion kit. LP gas installations will operate up to 10,000' (3048 m) without adjustment.
- ▶ A Wolf ventilation system is recommended. When installing a ventilation hood, refer to the specific requirements of the hood for the minimum dimension to cooking surface.

⚠ WARNING

This cooktop is intended for indoor use.

- ▶ *Dimensions in parentheses are in millimeters unless otherwise specified.*

Integrated Gas Multi-Function Cooktop

MODEL IM15/S

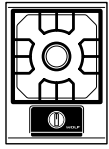

Model IM15/S
Classic Stainless Steel

High-output 18,000 Btu/hr
(5.3 kWh) burner

Wok grate shown

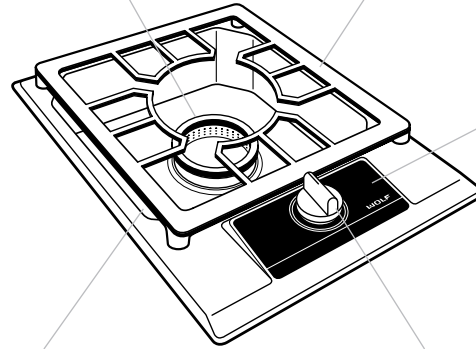

Illuminated
control panel

Deep drawn pan

Continuous
control knob

► The Wolf Model IM15/S 15" (381) gas multi-function cooktop is available in natural or LP gas, with classic stainless steel finish. The model number followed by (-LP) denotes an LP gas model.

It's really a misnomer to describe this wonderful cooktop as a wok instrument because it is much more than that. The large, low-profile grate will fit in nicely with any Wolf gas cooktop.

For true wok cooking, the burner sculpts the gas flame into a plume, focusing heat in the center of the wok, then dispersing it outward for precisely controlled cooking. The larger grate will handle your wok perfectly, but also accommodate even your largest stockpots, Dutch ovens and the like. The powerful burner exceeds 18,000 Btu/hr (5.3 kWh).

Let Wolf, the corporate companion and kitchen soul mate of Sub-Zero, fuel your passion for cooking and kitchen design.

Integrated Gas Multi-Function Cooktop

MODEL IM15/S - SPECIFICATIONS

FEATURES

- ▶ Integrated design allows for use with multiple cooktop units
- ▶ Available in natural and LP gas
- ▶ Stainless steel top construction with classic stainless steel finish
- ▶ High output 18,000 Btu/hr (5.3 kWh) sealed burner
- ▶ Automatic electronic re-ignition system
- ▶ Illuminated control panel
- ▶ Individual spark ignition system
- ▶ Two interchangeable cast iron burner grates with matte porcelain finish - wok grate and low profile continuous grate
- ▶ Deep drawn burner pan
- ▶ CSA certified for US and Canada
- ▶ Two and five year residential warranty - exclusions apply, see warranty at the end of this guide

OVERALL DIMENSIONS ▼

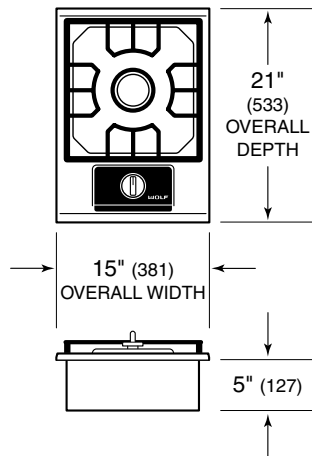

- ▶ Dimensions may vary by $\pm 1/8"$ (3).
- ▶ Dimensions in parentheses are in millimeters unless otherwise specified.

Integrated Gas Multi-Function Cooktop

MODEL IM15/S - SPECIFICATIONS

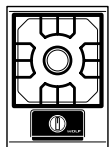

Model IM15/S
Classic Stainless Steel

TRIM FINISH

Classic Stainless Steel IM15/S

VENTILATION OPTIONS

- ▶ Chimney Wall or Island Hood
- ▶ Downdraft Ventilation System
- ▶ Pro Series Wall or Island Hood

Refer to the Wolf Cooktop Ventilation or Pro Series Ventilation sections for additional information.

ACCESSORIES

- ▶ Filler strip
- ▶ LP and natural gas conversion kits
- ▶ High altitude conversion kit

Contact your Wolf dealer for additional information on accessories.

SPECIFICATIONS

Overall Cooktop Width	15" (381)
Overall Cooktop Height	5" (127)
Overall Cooktop Depth	21" (533)
Cooktop Cut-out Width	14" (356)
Cooktop Cut-out Depth	19 1/4" (489)
Minimum Cabinet Depth	22 3/4" (578)
Surface Burner	18,000 Btu/hr (5.3 kWh)
Gas Rating	18,000 Btu/hr (5.3 kWh)
Electrical Supply Requirements	120 V AC, 60 Hz, 15 amp dedicated circuit
Power Cord	6' (1.8 m) power cord with 3-prong grounded plug
Shipping Weight	30 lbs (14 kg)
Special Note	Cooktop can be installed in combination with other cooktops

- ▶ Specifications are subject to change without notice.

▶ Dimensions in parentheses are in millimeters unless otherwise specified.

Integrated Gas Multi-Function Cooktop

INSTALLATION

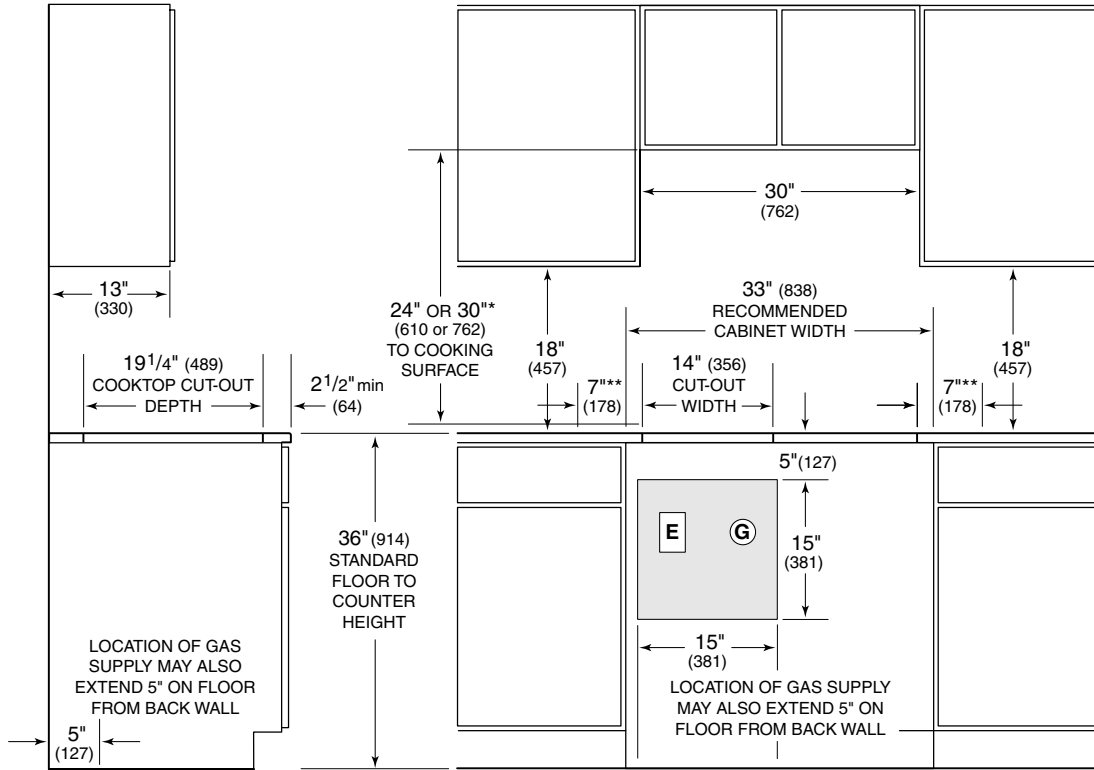

NOTE: Application shown allows for installation of two 15" (381) modules side-by-side.

* Minimum 24" (610) from protected cabinet or 30" (762) from unprotected cabinet to cooking surface.

** Minimum clearance from side edge of cooktop cut-out to combustible surface up to 18" (457) above cooking surface.

► Dimensions may vary by $\pm 1/8"$ (3).

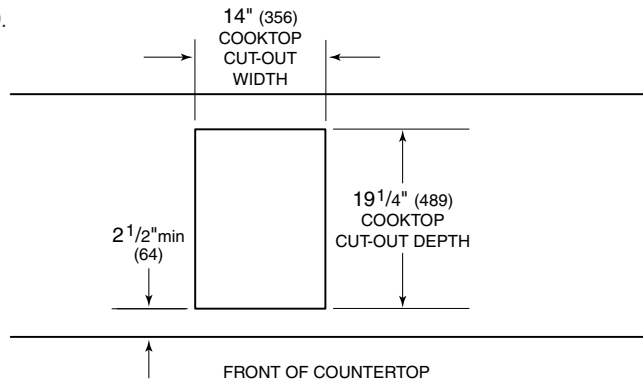

DIMENSIONS

Cooktop Cut-Out Width	14" (356)
Recommended Cabinet Width	33" (838)
Cooktop Cut-Out Depth	19 1/4" (489)
Location of Electrical and Gas Supply	Within shaded area

- See Installation Instructions shipped with unit for detailed specifications.
- Dimensions in parentheses are in millimeters unless otherwise specified.

Integrated Gas Multi-Function Cooktop

INSTALLATION

INSTALLATION NOTES

IMPORTANT NOTE: Review specific installation instructions for product to product capabilities

- ▶ Wolf recommends using 33" (838) cabinets with the 15" (381) cooktop.
- ▶ When multiple 15" (381) cooktop modules are installed side-by-side refer to the General Applications section for additional information.
- ▶ For the 15" (381) gas multi-function cooktop, the gas service may be supplied through the floor. Refer to the illustration for specifics on cut-out dimensions and placement of gas and electrical.
- ▶ The Wolf gas multi-function cooktop requires a separate 120V, 60 Hz power supply. The service should have its own 15 amp circuit breaker, and a grounded 3-prong receptacle should be located within the reach of the 6' (1.8 m) power cord.
- ▶ You must follow all National Electrical Code and gas regulations. In addition, be aware of local codes and ordinances when installing your services.

▶ The gas multi-function cooktop is designed to operate on natural gas at 5" WC (water column) pressure or LP gas at 10" (254) WC pressure. It is supplied with a 1/2" NPT female gas connection at the right rear corner of the cooktop.

▶ The Wolf gas multi-function cooktop functions up to 8,000' (2438 m) in altitude without any adjustment. If installation is above 8,000' (2438 m), contact your Wolf dealer.

▶ A Wolf ventilation system is recommended. When installing a ventilation hood, refer to the specific requirements of the hood for the minimum dimension to cooking surface.

▲ WARNING

This cooktop is intended for indoor use.

▶ *Dimensions in parentheses are in millimeters unless otherwise specified.*